

# 114<sup>-001</sup>

# Ritter®

by MIDMARK

Power  
Podiatry  
Chair

## Service and Parts Manual

Serial Number Prefix: L

This manual applies to units  
with Serial Numbers after  
37420, & L1000 thru L1138

**NO LONGER IN  
PRODUCTION**  
Some service parts may not  
be available for this product!

114<sup>-001</sup>

FOR USE BY MIDMARK  
TRAINED TECHNICIANS ONLY

# TABLE OF CONTENTS

Subject	Page
Important Instructions .....	2
Introduction .....	3
Parts Replacement .....	3
Headlock Adjustment .....	3
Removal & Replacement of Upholstered Sections .....	4
Removal & Replacement of Table Panels .....	6
Removal & Replacement of Motor Cover & Shrouds .....	7
Removal & Replacement of Rubberized Tread .....	8
Power System Operation & Maintenance .....	8
Removal & Replacement of Hydraulic Cylinders	
Back Cylinder .....	9
Tilt Cylinder .....	10
Foot Cylinder .....	11
Base Cylinder .....	12
Lift and Stabilizing Chain Adjustment .....	13
Hydraulic System	
Adding Oil .....	13
Oil Leaks .....	14
Footswitch	
Removal & Replacement of Footswitch .....	14
Removal & Replacement of Foot Control Switches .....	15
Removal & Replacement of Footswitch Cord .....	15
Foot Control Switch Adjustment .....	15
Removal & Replacement of Power System Parts	
Power Cord.. .....	16
Motor Capacitors .....	16
Anticavitation Solenoid Valve .....	16
Time Delay Relay .....	17
Ground Line Integrity Monitor (GLIM) .....	17
Motor/Pump .....	17
Motor/Pump Ass'y. ....	18
Adjustment of Flow Controls .....	19
Special Tools .....	19
Troubleshooting Guide .....	20
Hydraulic Flow Diagram .....	25
111 & 114 Wiring Diagram .....	27

# IMPORTANT INSTRUCTIONS

## Safety First

Throughout this manual are "Notes", "CAUTIONS", and "**DANGER**" warnings that call attention to particular procedures. The items are used as follows:

Note: A note is used to amplify an operating procedure, practice or condition.

CAUTION: A CAUTION IS USED FOR AN OPERATING PROCEDURE, PRACTICE, OR CONDITION WHICH, IF NOT CORRECTLY FOLLOWED, COULD RESULT IN EQUIPMENT DAMAGE.

**DANGER: A DANGER IS USED FOR AN OPERATING PROCEDURE, PRACTICE, OR CONDITION WHICH, IF NOT CORRECTLY FOLLOWED, COULD RESULT IN PERSONAL INJURY.**

For your personal safety all DANGER warnings are repeated here. Become thoroughly familiar with them and observe them at all times.

1. **KEEP HANDS, FINGERS AND ALL OTHER PARTS OF THE BODY AWAY FROM AND FREE OF MOVING PARTS. FAILURE TO FOLLOW THIS COULD RESULT IN PERSONAL INJURY.**
2. **ALWAYS DISCONNECT THE TABLE POWER CORD FROM THE WALL RECEPTACLE BEFORE ATTEMPTING ANY SERVICE OR MAINTENANCE OF THE EQUIPMENT. FAILURE TO DISCONNECT POWER CORD COULD RESULT IN PERSONAL INJURY OR EQUIPMENT DAMAGE.**
3. **DO NOT ATTEMPT TO REMOVE THE LEVER MECHANISM FROM THE UNDERSIDE OF THE FOOTREST. REMOVING THE LEVER MECHANISM COULD RESULT IN PERSONAL INJURY.**
4. **FAILURE TO LOCK THE FOOTREST SECTION INTO POSITION COULD RESULT IN PERSONAL INJURY OR EQUIPMENT DAMAGE.**
5. **DISCONNECT POWER CORD FROM WALL RECEPTACLE. FAILURE TO DISCONNECT POWER CORD COULD RESULT IN PERSONAL INJURY.**
6. **WHEN REPLACING THE WIRE RACEWAY, BE SURE ALL WIRES ARE CONFINED WITHIN RACEWAY. FAILURE TO CONTAIN WIRES COULD RESULT IN PERSONAL INJURY OR EQUIPMENT DAMAGE.**
7. **THE RECEPTACLE LEADS MUST BE CONNECTED TO THE CORRECT TERMINALS ON THE TERMINAL BOARD AND THE GREEN GROUNDING WIRE SECURELY ATTACHED TO THE TABLE BASE. FAILURE TO DO SO COULD RESULT IN EQUIPMENT DAMAGE OR AN ELECTRICAL SHOCK.**
8. **WHEN REPLACING THE MOTOR COVER, BE SURE ALL WIRES AND HOSES ARE INSIDE**

**OF COVER AND POWER CORD FITS IN SLOT IN COVER. FAILURE TO DO THIS COULD RESULT IN ELECTRICAL SHOCK OR EQUIPMENT DAMAGE.**

9. **DISCONNECT POWER CORD FROM WALL RECEPTACLE BEFORE REMOVING OR REPLACING MOTOR COVER AND SHROUDS. FAILURE TO DISCONNECT POWER CORD COULD RESULT IN PERSONAL INJURY.**
10. **FAILURE TO PERFORM A PERIODIC INSPECTION COULD RESULT IN PERSONAL INJURY OR EQUIPMENT DAMAGE.**
11. **WHEN CHANGING A CYLINDER, NOTE HOW THE WIRES, HOSES, HOSE FITTINGS, AND NYLON TIES ARE POSITIONED SO THAT THEY MAY BE REPLACED EXACTLY THE SAME WAY OR DAMAGE TO THE WIRES AND HOSES MAY OCCUR RESULTING IN ELECTRICAL SHOCK OR EQUIPMENT DAMAGE.**
12. **BACK SECTION MUST BE SUPPORTED UNTIL NEW CYLINDER IS INSTALLED. FAILURE TO SUPPORT BACK SECTION COULD RESULT IN PERSONAL INJURY OR EQUIPMENT DAMAGE.**
13. **BE SURE POWER CORD IS DISCONNECTED FROM WALL RECEPTACLE. FAILURE TO DISCONNECT POWER CORD COULD RESULT IN ELECTRICAL SHOCK.**
14. **TABLE TOP MUST BE SUPPORTED UNTIL NEW CYLINDER IS INSTALLED. FAILURE TO SUPPORT TABLE TOP COULD RESULT IN PERSONAL INJURY OR EQUIPMENT DAMAGE.**
15. **THREE PERSONS ARE REQUIRED TO CHANGE A BASE CYLINDER. TWO PERSONS MUST SUPPORT THE TABLE TOP AS THE THIRD PERSON REMOVES THE CYLINDER. FAILURE TO USE THREE PERSONS COULD RESULT IN PERSONAL INJURY OR EQUIPMENT DAMAGE.**
16. **WHEN REMOVING THE CLEVIS PINS FROM THE BASE CYLINDERS, THE TWO ASSISTANTS MUST SUPPORT THE TABLE TOP. KEEP HANDS AWAY FROM THE TOP OF THE SLIDES, POINT A, FIG. 21 AND FROM BENEATH THE BASE SLIDING MEMBER. AFTER REMOVING THE CYLINDER, STAND CLEAR OF THE TABLE AS THE TWO ASSISTANTS LOWER THE TABLE TOP. FAILURE TO DO THIS COULD RESULT IN SERIOUS PERSONAL INJURY.**
17. **HYDRAULIC OIL IN THIS EQUIPMENT IS UNDER HIGH PRESSURE WHEN EQUIPMENT IS IN OPERATION. NEVER CHECK OR ATTEMPT TO REPAIR ANY OIL LINE WITHOUT FIRST SHUTTING OFF THIS EQUIPMENT AND UNPLUGGING THE POWER CORD.**
18. **DONOTADJUSTTHESTOPMORETHANAN ADDITIONAL 1/2 TURN AFTER AUDIBLE CLICK IS HEARD. ADJUSTING THE STOP**

**MORE THAN 1/2 TURN MAY RESULT IN DAMAGE TO THE SWITCH OR PERSONAL INJURY.**

19. **BEFORE ATTEMPTING TO REMOVE AND REPLACE A POWER SYSTEM PART, DISCONNECT POWER CORD FROM WALL RECEPTACLE. FAILURE TO DISCONNECT POWER CORD COULD RESULT IN PERSONAL INJURY.**
20. **THE LOCATOR PIN ON THE BACK OF THE TIME DELAY RELAY MUST BE IN THE HOLE ON THE MOTOR BASE. FAILURE TO DO THIS COULD RESULT IN ELECTRICAL SHOCK.**
21. **WHEN REMOVING THE WIRES FROM THE TERMINAL BOARD, NOTE THE POSITION OF THE WIRES SO THAT THEY MAY BE REPLACED ON THE SAME TERMINALS. FAILURE TO DO THIS COULD RESULT IN EQUIPMENT DAMAGE OR PERSONAL INJURY.**
22. **DO NOT ATTEMPT ELECTRICAL CONTINUITY CHECKS OR ANY WIRING TESTS WITH THE TABLE PLUGGED INTO THE WALL OUTLET. FAILURE TO DISCONNECT POWER COULD RESULT IN ELECTRICAL SHOCK.**

To assure safer service and maintenance of this equipment:

1. Read this manual before servicing the equipment.
2. Be sure that you understand the instructions contained in this manual before attempting to service or repair the equipment.
3. **DANGER: KEEP HANDS, FINGERS AND ALL OTHER PARTS OF THE BODY AWAY FROM AND FREE OF MOVING PARTS. FAILURE TO FOLLOW THIS COULD RESULT IN PERSONAL INJURY.**
4. **DANGER: ALWAYS DISCONNECT THE TABLE POWER CORD FROM THE WALL RECEPTACLE BEFORE ATTEMPTING ANY SERVICE OR MAINTENANCE OF THE EQUIPMENT. FAILURE TO DISCONNECT POWER CORD COULD RESULT IN PERSONAL INJURY OR EQUIPMENT DAMAGE.**

Nothing herein shall be construed as a warranty or guarantee regarding the equipment, its operation or its suitability for any particular purpose. Express and implied warranties are herewith disclaimed by the manufacturer. The equipment has been designed in such a manner as to permit service and repair by dealer service personnel. However service and repairs shall be at the dealer's risk. In the event the dealer or his service personnel do not understand the instructions given or the nature of a malfunction experienced, a company salesman or a company service representative should be contacted.

## INTRODUCTION

This manual covers complete instructions for the service and maintenance of the Model III Medical Examination Table and Model 114 Power Podiatry Chair.

The Model 111 and 114 are similar in operation. All subjects covered pertain to both models unless otherwise specified. For the purpose of this manual, the word **table** is synonymous with the word **chair**.

## PARTS REPLACEMENT

The Model 111 & 114 examination tables have been designed so that mechanical and electrical components can easily be repaired and/or replaced in the field if they should become defective for any reason.

If a part replacement should be required, the part must be ordered direct from the factory. When any part is ordered, a complete description or part number is required, along with Serial Number and date of installation of the table must be supplied. For details of the exchange plan, write the plant. (For location of serial number tag, see Item B, Fig. 3).

## HEADLOCK ADJUSTMENT

Model 111: To adjust the holding action of the headlock, release the lock handle and loosen the lock screw Item A, Fig. 1, using a 3/32" allen wrench. With a 3/16" allen wrench or a 1/2" wrench, tighten the adjusting screw, Item B, Fig. 1, to obtain the greatest possible holding power without making the handle operation too difficult. Then with the handle in locked position, tighten the lock screw.

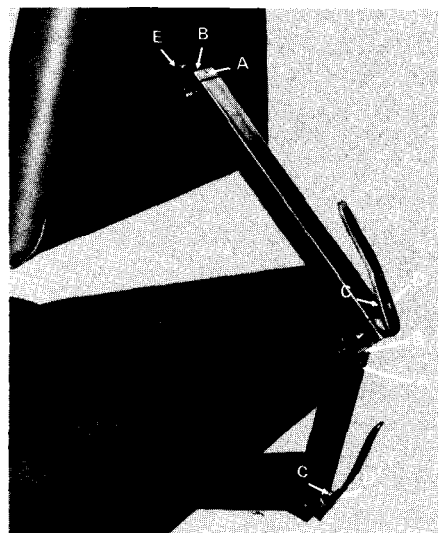

Fig. 1

Note: Light oil on the pivot points of the handle will help to a great degree the ease of operation of the handle.

In some rare cases, it may be necessary to adjust the handle stop to insure good holding power with ease of handle operation or to prevent the handle from springing loose under shock loads.

For proper action the handle stop must be adjusted so that when the handle is pushed down for locking action, the handle reaches a point where it wants to lock itself by suddenly going over center. The proper position of the stop is just a fraction over center. The stop is adjusted by loosening the lock nut Item C, Fig. 1 and turning the set screw stop Item D, Fig. 1 with a 1/8" allen wrench. After adjustment, lock the stop screw with the lock nut.

Model 114: To adjust the holding action of the headlock, release the lock handle and loosen the lock screw Item A, Fig. 2 using a 3/32" allen wrench. With a 3/16" allen wrench, tighten the adjusting screw Item B, Fig. 2 to obtain the greatest possible holding power without making the handle operation too difficult. Then with the handle in the locked position, tighten the lock screw.

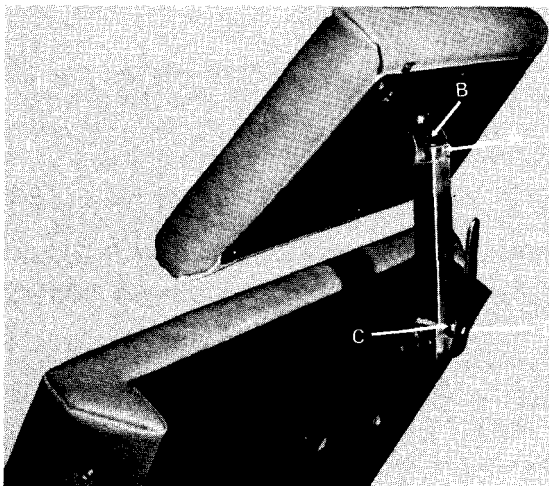

Fig. 2

Note: Light oil on the pivot points of the handle will help to a great degree the ease of operation of the handle.

In some rare cases, it may be necessary to adjust the handle stop to insure good holding power with ease of handle operation or to prevent the handle from springing loose under shock loads.

For proper action the handle stop must be adjusted so that when the handle is pushed down for locking action, the handle reaches a point where it wants to lock itself by suddenly going over the center. The proper position of the stop is just a fraction over center. The stop is adjusted by loosening the lock nut Item C, Fig. 2 and turning the set screw stop Item D, Fig. 2 with a 1/8" allen wrench. After adjustment, lock the stop screw with the lock nut.

## REMOVAL AND REPLACEMENT OF UPHOLSTERED SECTIONS

### Removal of Headrest Upholstery Section

- 1) Remove the (4) screws, Item E, Fig. 1, which mount the headrest to the brackets of the headlock.

### Replacement of Headrest Upholstery Section

- 1) Install the (4) #10-24x 5/8" screws through the metal brackets of the headlock and into the headrest. Tighten screws semi tight.
- 2) Align headrest square with back section and tighten screws securely.

### Removal of Seat & Back Upholstery Section

- 1) Remove the metal panel from the metal back frame by removing (4) small screws. Item A, Fig. 3.

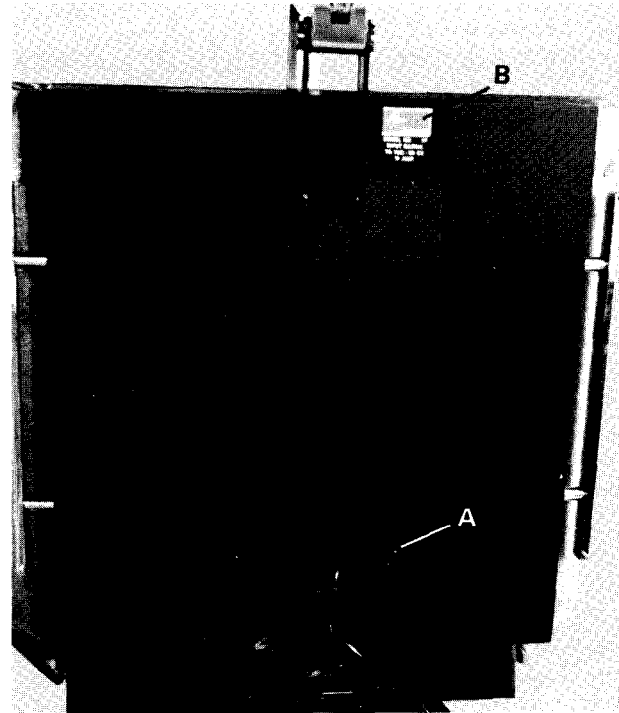

Fig. 3

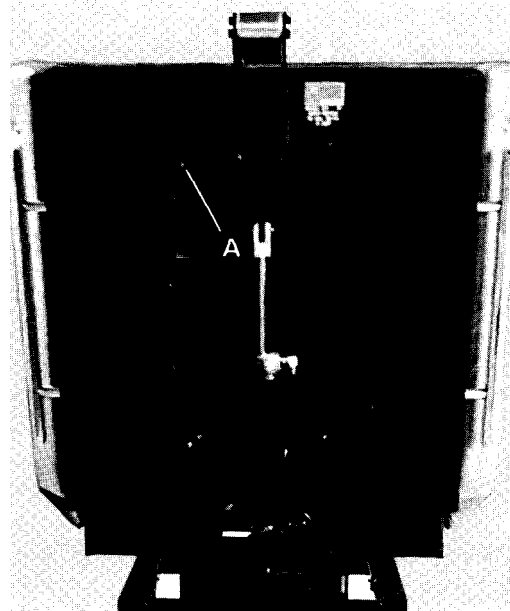

Fig. 4

- 2) Remove the (4) screws located inside the recessed area of the metal back frame. (Item A, Fig. 4).
- 3) Remove the (2) screws located at the front edge of the seat section. (Item A, Fig. 5) It is easiest to do this with the leg extension raised up.
- 4) Remove the (2) screws located under the seat section, near the hinge, by inserting a screwdriver through access hole, Item B, Fig. 5.
- 5) On the 114 Only, remove the (4) wood screws located under the front outer edge of the seat section. Item A, Fig. 6.
- 6) With an assistant, lift the entire seat and back section.

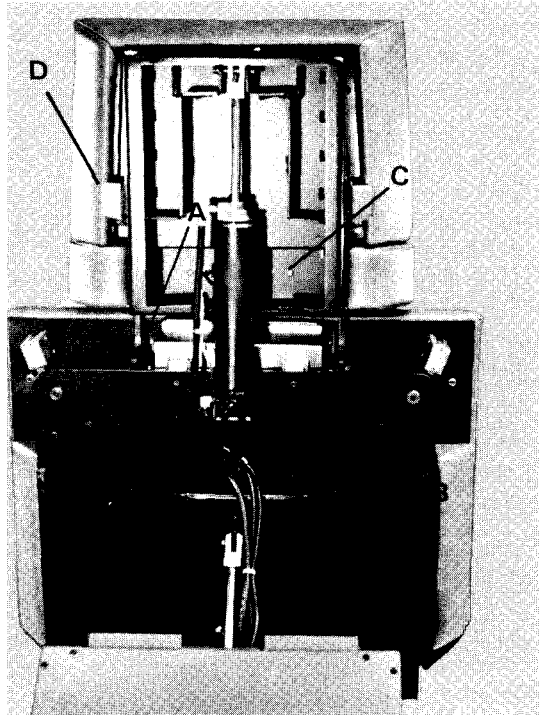

Fig. 5

### Replacement of Seat and Back Upholstery Section

- 1) With an assistant, place the seat and back upholstery section on the metal frame.
- 2) Align front holes under seat section, Item A, Fig. 5 and install (2)#10-24 x 5/8" screws. It is easiest to do this with leg extension raised up.
- 3) With a magnetic screwdriver, install (2)#10-24 x 5/8" screws through the access holes. Item B, Fig. 5.
- 4) Align holes on back section and install (4)#10-24 x 5/8" screws. Item A, Fig. 4.
- 5) On the 114 Only, install (4) wood screws under outer front edge of seat section, Item A, Fig. 6.

### Removal of Legrest Upholstered Section (111 Only)

- 1) Raise foot extension up, remove (2) #10-24 x 7/8" screws under the legrest frame, Item C, Fig. 5.

- 2) Lift off unholstered legrest.

### Replacement of Legrest Upholstered Section (111 Only)

- 1) With legrest extension raised up, place legrest upholstered section on the legrest frame.
- 2) Align holes and install (2) #10-24 x 7/8" screws under the legrest frame, Item C, Fig. 5.

### Removal of Footrest Upholstered Section (111 Only)

1. Remove footrest from table by lifting lever, Item D, Fig. 5, and pulling footrest toward you.

**DANGER: DO NOT ATTEMPT TO REMOVE THE LEVER MECHANISM FROM THE UNDERSIDE OF THE FOOTREST. REMOVING THE LEVER MECHANISM COULD RESULT IN PERSONAL INJURY.**

2. Return entire footrest to factory for replacement of upholstery.

### Replacement of Footrest Upholstered Section (111 Only)

1. When placing the footrest section in the position shown in Fig. 5, the metal guides should be inserted into the slots until you hear the mechanical locking device engage.

**DANGER: FAILURE TO LOCK THE FOOTREST SECTION INTO POSITION COULD RESULT IN PERSONAL INJURY OR EQUIPMENT DAMAGE.**

### Removal of Footrest Upholstered Section (114 Only)

- 1) Remove screw Item B, Fig. 6 from lateral locking mechanism to expose (4) mounting screws.
- 2) Remove (4) mounting screws from each side of frame, Item C, Fig. 6.
- 3) Pull upholstered section to its full extended position and lift.
- 4) Remove (4)#10-24 x 5/8" screws from upholstered foot section.

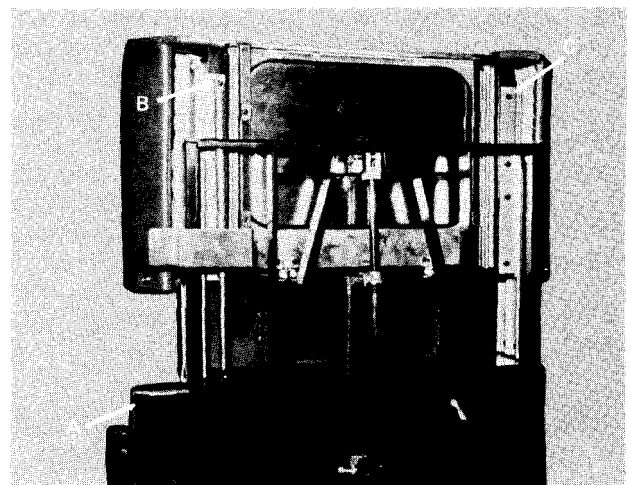

Fig. 6

## Replacement of the Footrest Upholstered Section (114 Only)

- 1) Place footrest upholstered section on frame and align holes and install (4) #10-24 x 5/8" screws in footrest upholstered section.
- 2) Install (4) mounting screws on each side of frame, Item C, Fig. 6.
- 3) Install screw, Item B, Fig. 6 in lateral locking mechanism.

## REMOVAL AND REPLACEMENT OF TABLE PANELS

- 1) Raise table to its highest position.

**DANGER: DISCONNECT POWER CORD FROM WALL RECEPTACLE. FAILURE TO DISCONNECT POWER CORD COULD RESULT IN PERSONAL INJURY.**

- 2) Remove motor cover, rear outershroud (motor end), and front outer shroud (foot end). See Motor Cover and Shroud Removal on Page 7.

### Removal of Left Panel Assembly and Table Panel from Shroud

- 3) Remove the white and black receptacle leads from the terminal board and the green grounding wire from the table base. See Wiring Diagram on Page 27.
- 4) Loosen wire clamp, Item A, Fig. 7 and remove wires from clamp.
- 5) Remove the panel assembly by removing the (3) screws, Item B, Fig. 7, located on the bottom flange.

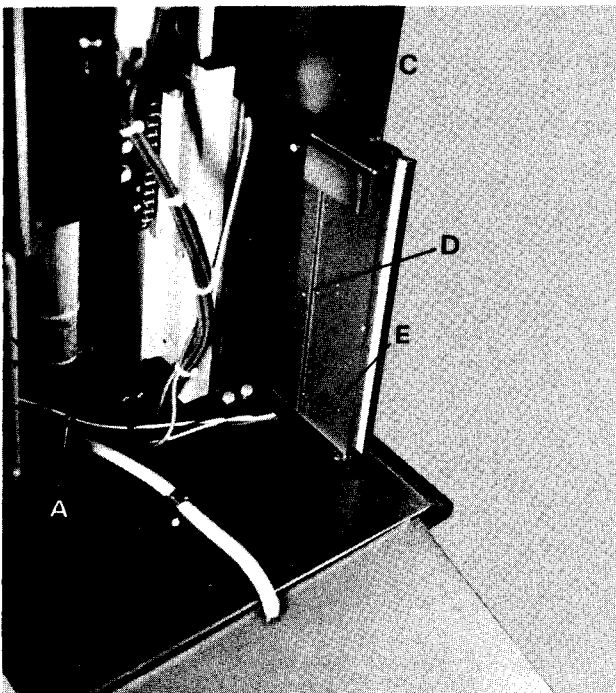

Fig. 7

- 6) Remove wire raceway by removing (6) screws, Item D, Fig. 7.

- 7) Remove receptacle cover by removing cover screw, Item A, Fig. 8, and screw on back side of shroud, Item C, Fig. 7.

- 8) Remove receptacle housing by removing (4) screws, Item A, Fig. 9.

- 9) Remove (4) panel mounting screws, Item E, Fig. 7.

### Replacement of Table Panel on Shroud and Left Panel Assembly on Table

- 10) Place new table panel on metal shroud, align holes, and install (4) #6 x 1/2" screws, Item E, Fig. 7.

- 11) Insert receptacle housing into panel cutout, align holes, and install (4) #6 x 1/2" screws, Item A, Fig. 9.

- 12) Replace receptacle cover, align holes, and install (1) #6-32 x 1/2" cover screw, Item A, Fig. 8 and (1) #10-24 x 7/8" screw, Item C, Fig. 7.

- 13) Replace wire raceway, align holes, and install (6) #6 x 1/2" screws, Item D, Fig. 7.

**DANGER: WHEN REPLACING THE WIRE RACEWAY, BE SURE ALL WIRES ARE CONFINED WITHIN RACEWAY. FAILURE TO CONTAIN WIRES COULD RESULT IN PERSONAL INJURY OR EQUIPMENT DAMAGE.**

- 14) Place panel assembly on table base, align holes, and install using (3) #10 x 3/8" screws, Item B, Fig. 7.

- 15) Insert wires through wire clamp and tighten clamp.

- 16) Attach the white and black receptacle leads to terminal board and the green grounding wire to the table base (using a #10 x 3/8" screw). See Wiring Diagram on Page 27.

**DANGER: THE RECEPTACLE LEADS MUST BE CONNECTED TO THE CORRECT TERMINALS ON THE TERMINAL BOARD AND THE GREEN GROUNDING WIRE SECURELY ATTACHED TO THE TABLE BASE. FAILURE TO DO SO COULD RESULT IN EQUIPMENT DAMAGE OR AN ELECTRICAL SHOCK.**

### Removal of Right Panel Assembly and Table Panel from Shroud.

- 1) Remove the panel assembly by removing the (3) screws located on the bottom flange.

- 2) Remove the table panel from the shroud by removing (4) mounting screws located on the back of the panel assembly.

### Replacement of Table Panel on Shroud and Right Panel Assembly on Table

- 3) Place new table panel on metal shroud, align holes, and install (4) #6 x 1/2" screws through the shroud into the panel.

- 4) Place panel assembly on table base, align holes, and install using (3) #10 x 3/8" screws through the bottom flange into the table base.

- 5) After exchanging panel assemblies, replace outer shroud (motor end), motor cover, and

outer shroud (foot end). See Replacement of Motor Cover and Shrouds on Page 7.

**DANGER: WHEN REPLACING THE MOTOR COVER, BE SURE ALL WIRES AND HOSES ARE INSIDE OF COVER AND POWER CORD FITS IN SLOT IN COVER. FAILURE TO DO THIS COULD RESULT IN ELECTRICAL SHOCK OR EQUIPMENT DAMAGE.**

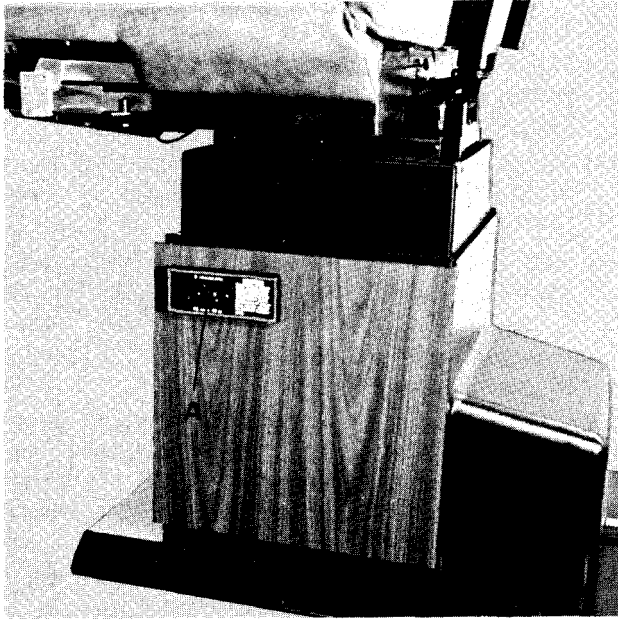

Fig. 8

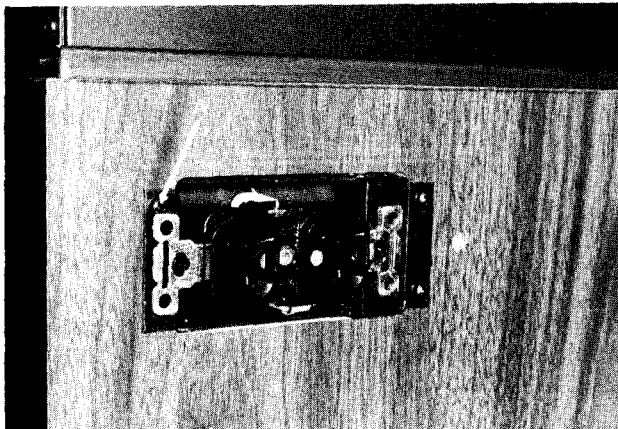

Fig. 9

## REMOVAL AND REPLACEMENT OF MOTOR COVER AND SHROUDS

**DANGER: DISCONNECT POWER CORD FROM WALL RECEPTACLE BEFORE REMOVING OR REPLACING MOTOR COVER AND SHROUDS. FAILURE TO DISCONNECT POWER CORD COULD RESULT IN PERSONAL INJURY.**

### Motor Cover

- 1) Remove motor cover by removing (6) screws, Item A, Fig. 10 and pulling bottom of cover out until top of cover disengages from retaining channel.
- 2) Replace motor cover by inserting top of cover into retaining channel, Item B, Fig. 10 and

pushing bottom of cover in until top is fully engaged in channel. Align holes and install (6) #10 x 3/8" screws, Item A, Fig. 10.

**DANGER: WHEN REPLACING THE MOTOR COVER, BE SURE ALL WIRES AND HOSES ARE INSIDE OF COVER AND POWER CORD FITS IN SLOT IN COVER. FAILURE TO DO THIS COULD RESULT IN ELECTRICAL SHOCK OR EQUIPMENT DAMAGE.**

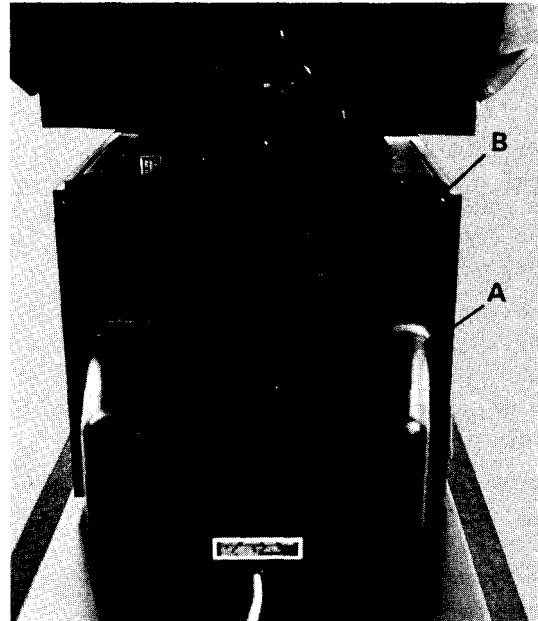

Fig. 10

### Rear Outer Shroud (Motor End)

- 1) Remove rear outer shroud by removing (4) screws, Item A, Fig. 11.
- 2) Replace rear outer shroud by placing shroud in position as shown in Fig. 11, aligning holes, and installing (4) #6 x 3/8" screws, Item A, Fig. 11.

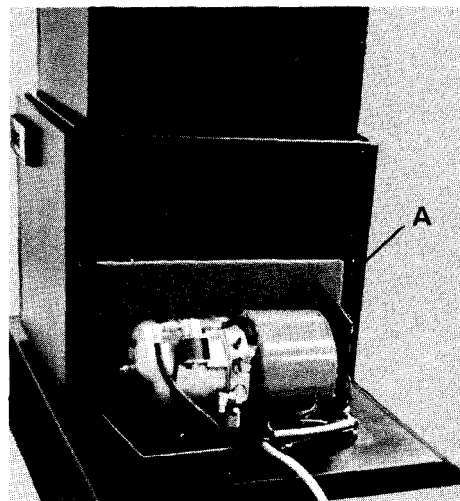

Fig. 11

### Rear Inner Shroud (Motor End)

- 1) Remove rear inner shroud by removing (8) screws, Item A, Fig. 12.



- 2) Replace rear inner shroud by placing shroud in position as shown in Fig. 12, aligning holes, and installing (8) #6 x 3/8" screws, Item A, Fig. 12.

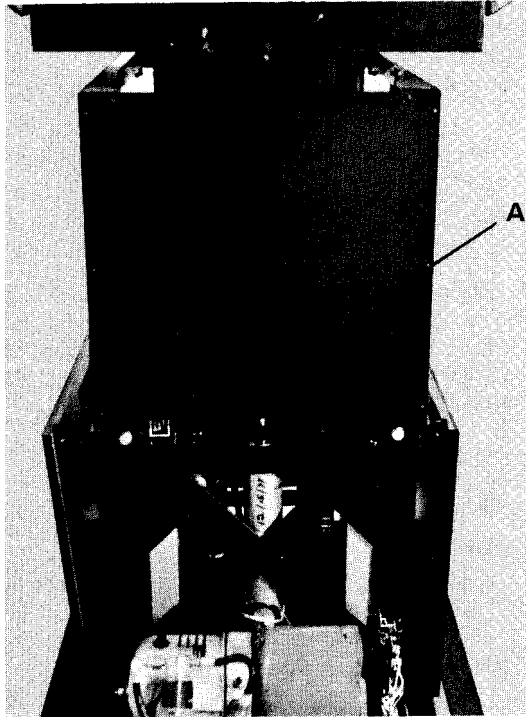

Fig. 12

### Front Outer Shroud (Foot End)

- 1) Remove front outer shroud by removing (6) screws, Item A, Fig. 13.
- 2) Replace front outer shroud by placing shroud in position as shown in Fig. 13, aligning holes and installing (6) #6 x 3/8" screws, Item A, Fig. 13.

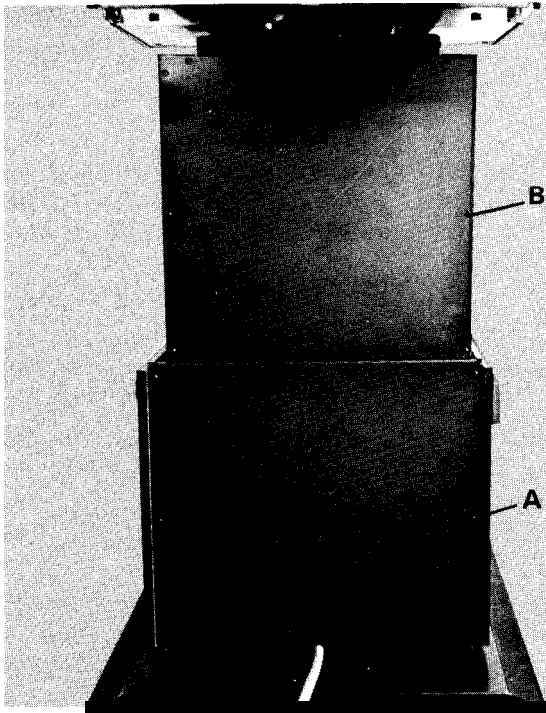

Fig. 13

### Front Inner Shroud (Foot End)

- 1) Remove front inner shroud by removing (8) screws, Item B, Fig. 13.
- 2) Replace front inner shroud by placing shroud in position as shown in Fig. 13, aligning holes, and installing (8) #6 x 3/8" screws, Item B, Fig. 13.

## REMOVAL AND REPLACEMENT OF RUBBERIZED TREAD

The rubberized tread on the tapered sides of the table base may be replaced by:

- 1) Remove tread by grasping end of tread and peeling off of table base.
- 2) Remove all foreign material from base where tread is to be applied.
- 3) Peel off paper backing on new tread, place tread in position, and firmly press on tread making sure all edges adhere to the base.

Note: Base surface must be clean and dry before application of new tread.

## POWER SYSTEM OPERATION AND MAINTENANCE

The power system consists of three basic sub assemblies:

1. An electric motor coupled to a hydraulic pump with an attached oil reservoir.
2. Four hydraulic cylinders with built-in electric solenoid valves.
3. A foot control footswitch assembly.

When the control switch, either Table Up, Back Up, Tilt Up, or Foot Up is depressed, it opens a solenoid valve in the cylinder and simultaneously energizes the motor which pumps oil from the reservoir into the bottom of the respective cylinder. This extends the pistons of the cylinder to the desired length. When the control switch is released, the motor stops and the solenoid valve closes automatically locking the cylinder piston in that position. When the control switch, either Table Down, Back Down, Tilt Down, or Foot Down is depressed, the solenoid valve is again opened and simultaneously the motor reverses which pumps oil from the reservoir into the top of the cylinder and retracts the piston to the desired length. When the control switch is released, the motor stops and the solenoid valve closes automatically locking the cylinder piston in that position.

The solenoid valves are built into the cylinders, eliminating the high pressure condition in the hoses when the motor is not running. This feature reduces the number of components subjected to high pressure when the motor is not running.

The motor, pump and reservoir of the power system are enclosed in a sounddeadened housing located on the base plate.

Little routine maintenance is required other than a periodic inspection of hydraulic hose lines and electrical cords to make sure they are free of cuts or damage and clear of moving parts. Due to the mechanical, electrical nature of this equipment, periodic inspections at six (6) month intervals are recommended.

**DANGER: FAILURE TO PERFORM A PERIODIC INSPECTION COULD RESULT IN PERSONAL INJURY OR EQUIPMENT DAMAGE.**

## REMOVAL AND REPLACEMENT OF HYDRAULIC CYLINDERS

### Back Cylinder

**DANGER: WHEN CHANGING A CYLINDER, NOTE HOW THE WIRES, HOSES, HOSE FITTINGS, AND NYLON TIES ARE POSITIONED SO THAT THEY MAY BE REPLACED EXACTLY THE SAME WAY OR DAMAGE TO THE WIRES AND HOSES MAY OCCUR RESULTING IN ELECTRICAL SHOCK OR EQUIPMENT DAMAGE. See Figs. 14 & 15.**

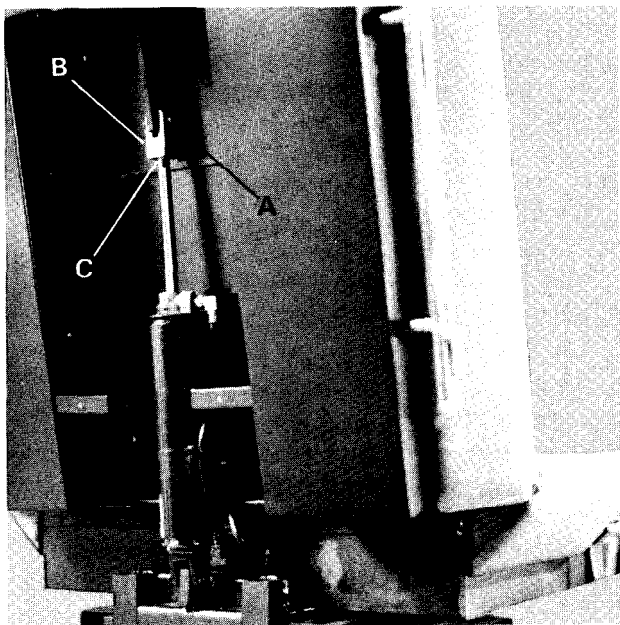

Fig. 14

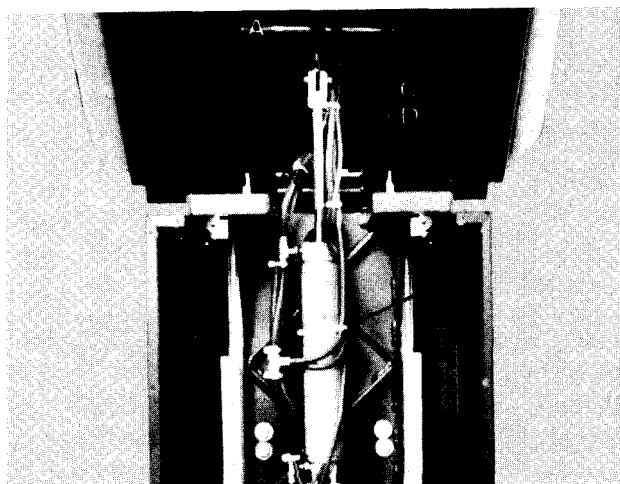

Fig. 15

**DANGER: DISCONNECT POWER CORD FROM WALL RECEPTACLE. FAILURE TO DISCONNECT POWER CORD COULD RESULT IN PERSONAL INJURY.**

- 1) Remove motor cover, front outer shroud (foot end), and front inner shroud (foot end). See Motor Cover & Shroud Removal on Page 7.
- 2) Remove back cover shroud from back section by removing (4) screws, Item A, Fig. 3.
- 3) With an assistant supporting the back section, remove the "E" ring and clevis pin, Item A, Fig. 14 and let the cylinder hang down. See Fig. 16.

**DANGER: BACK SECTION MUST BE SUPPORTED UNTIL NEW CYLINDER IS INSTALLED. FAILURE TO SUPPORT BACK SECTION COULD RESULT IN PERSONAL INJURY OR EQUIPMENT DAMAGE.**

- 4) Remove large nylon tie, Item A, Fig. 16 from cylinder.
- 5) Remove nylon tie, Item B, Fig. 16 from flex-guard tubing.
- 6) Remove the (2) hose fittings from the defective cylinder using a 1/2" wrench.

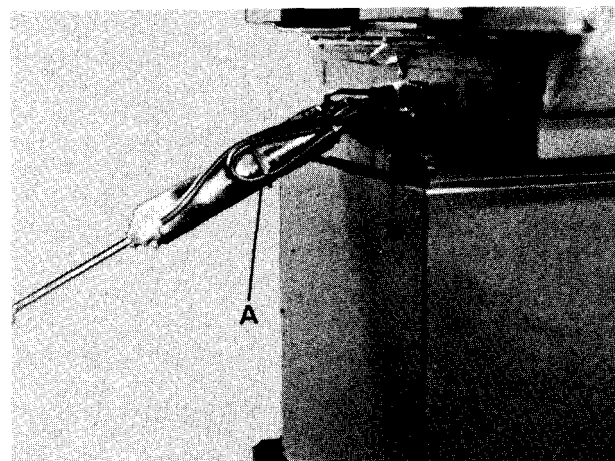

Fig. 16

**DANGER: BE SURE POWER CORD IS DISCONNECTED FROM WALL RECEPTACLE. FAILURE TO DISCONNECT POWER CORD COULD RESULT IN ELECTRICAL SHOCK.**

- 7) Cut the solenoid electric cord off at least 6" from the defective cylinder.
- 8) Remove "E" ring and clevis pin from valve end of cylinder to remove cylinder from table.
- 9) Place new cylinder in position and install clevis pin and "E" ring at valve end of cylinder.
- 10) Connect hose fittings tightly to new cylinder. Lay solenoid electric cord along side of hoses inside of flex-guard tubing.
- 11) Install large nylon tie, Item A, Fig. 16, on the cylinder.
- 12) Install nylon tie, Item B, Fig. 16, around the flex-guard to contain the hoses and solenoid wire.

- 13) Follow defective cylinder solenoid cord from cylinder to terminal board, noting the placement of nylon ties and clamps.
- 14) Lay new cylinder solenoid cord along side of defective cylinder solenoid cord, replacing ties and clamps as you remove the defective cylinder cord and replace with new cylinder cord.

**DANGER: BE SURE POWER CORD IS DISCONNECTED FROM WALL RECEPTACLE. FAILURE TO DISCONNECT POWER CORD COULD RESULT IN ELECTRICAL SHOCK.**

- 15) Remove defective cylinder cord from terminal board and replace with new cylinder cord. See Wiring Diagram on Page 27.
- 16) Temporarily plug the power cord into an electrical outlet and fully extend the back cylinder rod by depressing the "Back Up" footswitch pedal.
- 17) Position the back section and back cylinder as shown in Fig. 14 and install clevis pin and "E" ring, Item A, Fig. 14.
- 18) After installation of new cylinder, check to see that all cords and hoses work freely and are clear of obstructions.
- 19) Position the table as shown in Fig. 17. The table top should be level. If the back section tilts down, then adjust the clevis, Item B, Fig. 14 out. If the back section tilts up, then adjust the clevis, Item B, Fig. 14 in. To adjust the clevis, turn the cylinder rod using a 3/8" open end wrench. The rod will turn easiest when it is extended about half of its total extension.

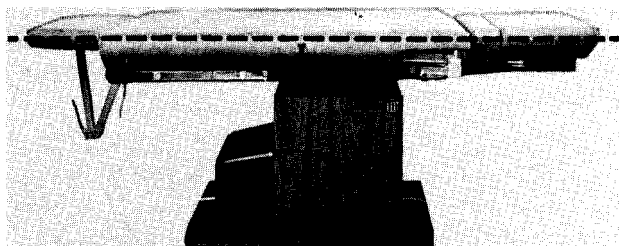

Fig. 17

**DANGER: DISCONNECT POWER CORD FROM WALL RECEPTACLE. FAILURE TO DISCONNECT POWER CORD COULD RESULT IN PERSONAL INJURY.**

- 20) If loss of hydraulic fluid was excessive during repair, oil must be added to the system. Oil level should be checked and oil replenished if required. See Adding Oil to Hydraulic System on Page 13.
- 21) Place back cover shroud in position, align holes, and install (4) #6x 1/4" screws, Item A, Fig. 3.

- 22) Replace shrouds and motor cover. See Replacement of Motor Cover & Shrouds on Page 7.

### Tilt Cylinder

**DANGER: WHEN CHANGING A CYLINDER, NOTE HOW THE WIRES, HOSES, HOSE FITTINGS, AND NYLON TIES ARE POSITIONED SO THAT THEY MAY BE REPLACED EXACTLY THE SAME WAY OR DAMAGE TO THE WIRES AND HOSES MAY OCCUR RESULTING IN ELECTRICAL SHOCK OR EQUIPMENT DAMAGE. See Fig. 15.**

**DANGER: DISCONNECT POWER CORD FROM WALL RECEPTACLE. FAILURE TO DISCONNECT POWER CORD COULD RESULT IN PERSONAL INJURY.**

- 1) Remove motor cover, front outer shroud (foot end), and front inner shroud (foot end). See Motor Cover & Shroud Removal on Page 7.
- 2) With an assistant supporting the table top, remove the "E" ring and clevis pin, Item A, Fig. 15

**DANGER: TABLE TOP MUST BE SUPPORTED UNTIL NEW CYLINDER IS INSTALLED. FAILURE TO SUPPORT TABLE TOP COULD RESULT IN PERSONAL INJURY OR EQUIPMENT DAMAGE.**

- 3) Remove the large nylon tie, Item B, Fig. 15 from the cylinder.

**DANGER: BE SURE POWER CORD IS DISCONNECTED FROM WALL RECEPTACLE. FAILURE TO DISCONNECT POWER CORD COULD RESULT IN ELECTRICAL SHOCK.**

- 4) Cut the solenoid electric cord off at least 3" from the defective cylinder.
- 5) While supporting the defective cylinder, remove (2) hose fittings from the cylinder using a 1/2" wrench and remove the "E" ring and clevis pin from valve end of cylinder to remove cylinder from the table.
- 6) Place new cylinder in position. Install clevis pin and "E" ring at valve end of cylinder and connect hose fittings tightly.
- 7) Install large nylon tie, Item B, Fig. 15 on the cylinder.
- 8) Follow defective cylinder solenoid cord from cylinder to terminal board, noting the placement of nylon ties and clamps.
- 9) Lay new cylinder solenoid cord along side of defective cylinder solenoid cord, replacing ties and clamps as you remove the defective cylinder cord and replace with new cylinder cord.

**DANGER: BE SURE POWER CORD IS DISCONNECTED FROM WALL RECEPTACLE. FAILURE TO DISCONNECT POWER CORD COULD RESULT IN ELECTRICAL SHOCK.**

- 10) Remove defective cylinder cord from terminal board and replace with new cylinder cord. See Wiring Diagram on Page 27.

- 11) Temporarily plug the power cord into an electrical outlet and extend the tilt cylinder rod by depressing the "Tilt Up" footswitch pedal.
- 12) Position the table top and tilt cylinder as shown in Fig. 15 and install clevis pin and "E" ring, Item A, Fig. 15.
- 13) After installation of new cylinder, check to see that all cords and hoses work freely and are clear of obstructions.
- 14) Position the table as shown Fig. 17. The table top should be level. If the top is not level, the clevis, Item C, Fig. 15, must be adjusted in or out accordingly. To adjust the clevis, turn the cylinder rod using a 3/8" open end wrench on the wrenching flats, Item D, Fig. 15. The rod will turn easiest when it is extended about half of its total extension.

**DANGER: DISCONNECT POWER CORD FROM WALL RECEPTACLE. FAILURE TO DISCONNECT POWER CORD COULD RESULT IN PERSONAL INJURY.**

- 15) If loss of hydraulic fluid was excessive during repair, oil must be added to the system. Oil level should be checked and oil replenished if required. See Adding Oil to Hydraulic System on Page 13.
- 16) Replace shrouds and motor cover. See Replacements of Motor Cover & Shrouds on Page 7.

### Foot Cylinder

**DANGER: WHEN CHANGING THE CYLINDER, NOTE HOW THE WIRES, HOSES, HOSE FITTINGS, AND NYLON TIES ARE POSITIONED SO THAT THEY MAY BE REPLACED EXACTLY THE SAME WAY OR DAMAGE TO THE WIRES AND HOSES MAY OCCUR RESULTING IN ELECTRICAL SHOCK OR EQUIPMENT DAMAGE. See Figs. 15 & 18.**

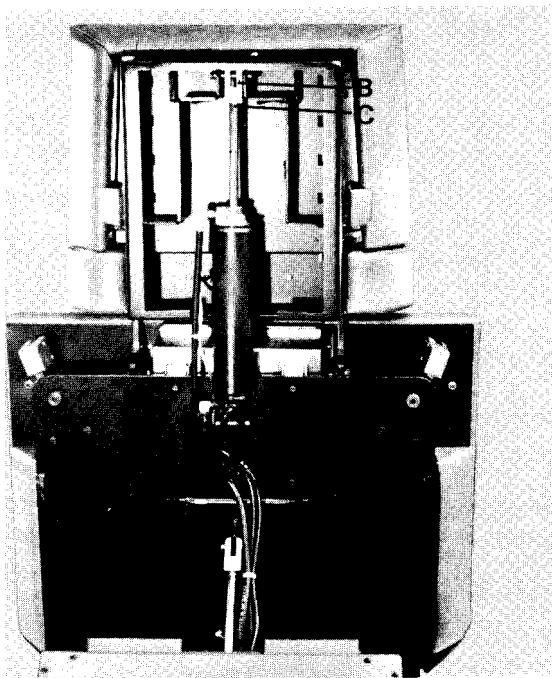

Fig. 18

- 1) Position the table as shown in Fig. 18.

**DANGER: DISCONNECT POWER CORD FROM WALL RECEPTACLE. FAILURE TO DISCONNECT POWER CORD COULD RESULT IN PERSONAL INJURY.**

- 2) Remove motor cover, front outer shroud (foot end), and front inner shroud (foot end). See Motor Cover & Shroud Removal on Page 7.
- 3) Loosen hose clamp, Item A, Fig. 18.

**DANGER: BE SURE POWER CORD IS DISCONNECTED FROM WALL RECEPTACLE. FAILURE TO DISCONNECT POWER CORD COULD RESULT IN PERSONAL INJURY.**

- 4) Cut the solenoid electric cord off at least 6" from the defective cylinder.
- 5) Remove the (2) hose fittings from the defective cylinder using a 1/2" wrench.
- 6) With an assistant supporting the footrest frame, remove the defective cylinder by removing the cotter pin and clevis pin from the rod end of the cylinder and the "E" ring and clevis pin from the valve end of the cylinder.
- 7) Place the new cylinder in position and install the clevis pin and "E" ring at the valve end of the cylinder and the clevis pin and cotter pin at the rod end of the cylinder.
- 8) Connect the hose fittings tightly to new cylinder.
- 9) Follow defective cylinder solenoid cord from cylinder to terminal board, noting the placement of nylon ties and clamps.
- 10) Lay new cylinder solenoid cord along side of defective cylinder solenoid cord, replacing ties and clamps as you remove the defective cylinder cord and replace with the new cylinder cord.

**DANGER: BE SURE POWER CORD IS DISCONNECTED FROM WALL RECEPTACLE. FAILURE TO DISCONNECT POWER CORD COULD RESULT IN ELECTRICAL SHOCK.**

- 11) Remove defective cylinder cord from terminal board and replace with new cylinder cord. See Wiring Diagram on Page 27.
- 12) After installation of new cylinder, check to see that all cords and hoses work freely and are clear of obstructions.
- 13) Temporarily plug the power cord into an electrical outlet and position the table as shown in Fig. 17. The table top should be level. If the top is not level, the clevis, Item B, Fig. 18 must be adjusted in or out accordingly. To adjust the clevis, turn the cylinder rod using a 3/8" open end wrench on the wrenching flats, Item C, Fig. 18. The rod will turn easiest when it is extended about half of its total extension.

**DANGER: DISCONNECT POWER CORD FROM WALL RECEPTACLE. FAILURE TO DISCONNECT POWER CORD COULD RESULT IN PERSONAL INJURY.**

- 14) If loss of hydraulic fluid was excessive during repair, oil must be added to the system. Oil level should be checked and oil replenished if required. See Adding Oil to Hydraulic System on Page 13.
- 15) Replace shroud and motor cover. See Replacement of Motor Cover & Shrouds on Page 7.

### Base Cylinder

**DANGER: THREE PERSONS ARE REQUIRED TO CHANGE A BASE CYLINDER. TWO PERSONS MUST SUPPORT THE TABLE TOP AS THE THIRD PERSON REMOVES THE CYLINDER. FAILURE TO USE THREE PERSONS COULD RESULT IN PERSONAL INJURY OR EQUIPMENT DAMAGE.**

**DANGER: WHEN CHANGING A CYLINDER, NOTE HOW THE WIRES, HOSES, HOSE FITTINGS, AND NYLON TIES ARE POSITIONED SO THAT THEY MAY BE REPLACED EXACTLY THE SAME WAY OR DAMAGE TO THE WIRES AND HOSES MAY OCCUR RESULTING IN ELECTRICAL SHOCK OR EQUIPMENT DAMAGE. See Fig. 14 & 19.**

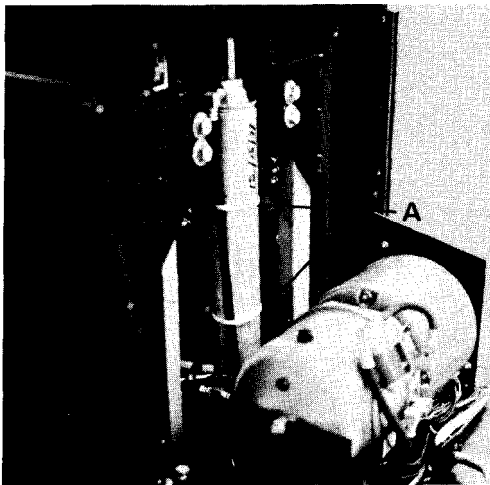

Fig. 19

**DANGER: DISCONNECT POWER CORD FROM WALL RECEPTACLE. FAILURE TO DISCONNECT POWER CORD COULD RESULT IN PERSONAL INJURY.**

- 1) Remove motor cover, rearoutershroud (motor end), and rear inner shroud (motor end). See Motor Cover & Shroud Removal on Page 7.
- 2) Remove "X" brace by removing (4) bolts with a 9/16" wrench.
- 3) Remove large nylon ties, Item A, Fig. 19 from cylinder.

**DANGER: BE SURE POWER CORD IS DISCONNECTED FROM WALL RECEPTACLE. FAILURE TO DISCONNECT POWER CORD COULD RESULT IN ELECTRICAL SHOCK.**

- 4) Follow cylinder solenoid cord to terminal board and remove cord from terminal board.
- 5) With two assistants lifting on the table top at

points A, Fig. 20, one assistant on each side of the table:

- a. remove the (2) hose fittings from the defective cylinder with a 1/2" wrench.
- b. remove cotter pins and clevis pins from each end of cylinder to remove cylinder from table.
- c. after cylinder is removed from the table, have the assistants slowly lower the table top to its lowest height.

**DANGER: WHEN REMOVING THE CLEVIS PINS FROM THE BASE CYLINDERS, THE TWO ASSISTANTS MUST SUPPORT THE TABLE TOP. KEEP HANDS AWAY FROM THE TOP OF THE SLIDES, POINT A, FIG. 21 AND FROM BENEATH THE BASE SLIDING MEMBER. AFTER REMOVING THE CYLINDER, STAND CLEAR OF THE TABLE AS THE TWO ASSISTANTS LOWER THE TABLE TOP. FAILURE TO DO THIS COULD RESULT IN SERIOUS PERSONAL INJURY.**

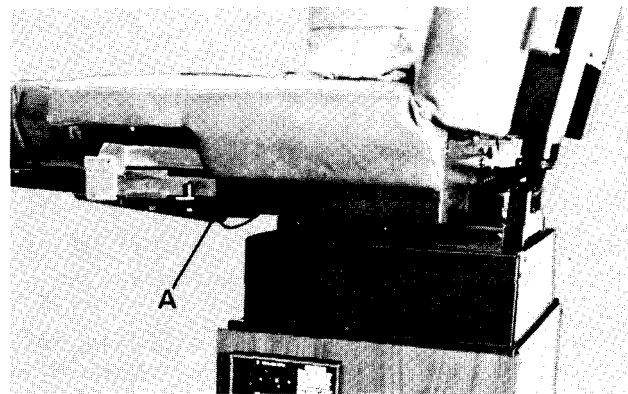

Fig. 20

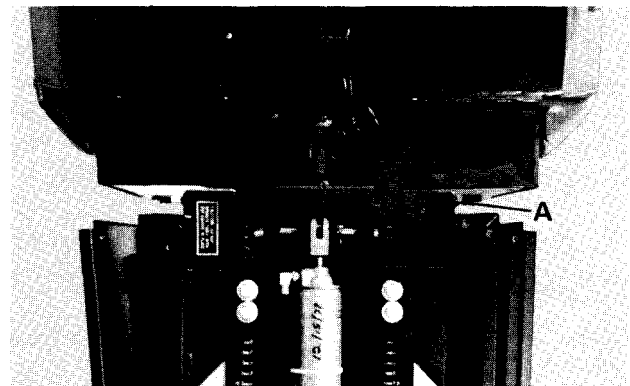

Fig. 21

- 6) Place new cylinder in position and install clevis pin and cotter pin at valve end of cylinder.
- 7) Connect the (2) hose fittings tightly to the new cylinder.
- 8) Have the two assistants lift on the table top enabling the clevis pin, Item B, Fig. 21 to be installed along with the cotter pin.
- 9) Install the large nylon ties, Item A, Fig. 19 on the cylinder.

- 10) Install new cylinder solenoid cord on terminal board. See Wiring Diagram on Page 27.
- 11) Temporarily plug the power cord into an electrical outlet and extend and retract the base cylinder a few times by depressing the "Table Up & Down" footswitch pedals alternately.
- 12) Fully retract the base cylinder and adjust for a 1/16" to 1/8" gap "A", Fig. 21 above the slides. To adjust for this gap, the clevis (rod end) must be adjusted in or out accordingly. To adjust the clevis, turn the cylinder rod using a 3/8" open end wrench on the wrenching flats, Item C, Fig. 21. The rod will turn easiest when it is extended about half of its total extension.

**CAUTION: FAILURE TO ADJUST FOR A 1/16" TO 1/8" GAP AND NO MORE THAN THIS COULD RESULT IN EQUIPMENT DAMAGE.**

**DANGER: DISCONNECT POWER CORD FROM WALL RECEPTACLE. FAILURE TO DISCONNECT POWER CORD COULD RESULT IN PERSONAL INJURY.**

- 13) If loss of hydraulic fluid was excessive during repair, oil must be added to the system. Oil level should be checked and oil replenished if required. See Adding Oil to Hydraulic System on Page 13.
- 14) Replace "X" brace, align holes, and install (4) 3/8" - 16 x 7/8" hex head bolts and (4) 3/8" lockwashers.
- 15) Replace shrouds and motor cover. See Replacement of Motor Cover & Shrouds on Page 7.

## LIFT AND STABILIZING CHAIN ADJUSTMENT

Excessive sideways play of the table may be due to loose chains. Chain looseness will be noticed only on the lower portion of the chain loop near the idler sprockets (see Fig. 22). Adjustments may be done as follows:

- 1) Raise the table to the highest position by depressing the "Table Up" footswitch pedal until the table stops rising.

**DANGER: DISCONNECT POWER CORD FROM WALL RECEPTACLE. FAILURE TO DISCONNECT POWER CORD COULD RESULT IN PERSONAL INJURY.**

- 2) Remove front outer shroud (foot end) and front inner shroud (foot end). See Shroud Removal on Page 7.
- 3) Loosen the (4) bolts, Item A, Fig. 22 with a 9/16" wrench.
- 4) Insert a prybar or large screwdriver in the center of the slot, Item B, Fig. 22 and pry up firmly. While prying up, tighten the (4) bolts, Item A, Fig. 22. The chains should not be drum tight, but with a little spring back and there should be equal tension in both chains.

- 5) Replace front outer shroud and front inner shroud. See Shroud Replacement on Page 7.

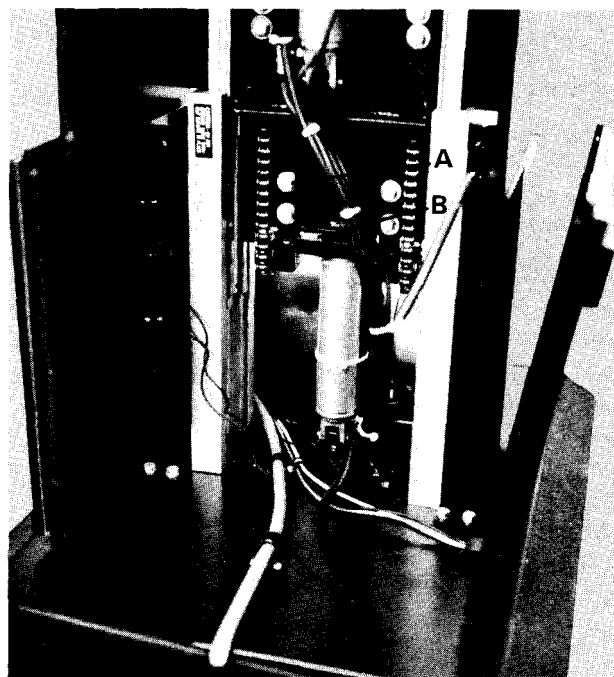

Fig. 22

## HYDRAULIC SYSTEM

The hydraulic oil used in the Model 111 & 114 power system is a colorless, odorless, nonstaining LIGHT GRADE mineral oil. This is the same grade of mineral oil as available from any hospital stockroom or pharmacy.

The unit is filled at the factory and should never need refilling unless fluid is lost through an external leak. No bleeding or purging of the hydraulic hoses is required. Any air that may reach the cylinder during shipment or during repairs will return to the reservoir after a short period of operation.

### Adding Oil to Hydraulic System

**DANGER: DISCONNECT POWER CORD FROM WALL RECEPTACLE. FAILURE TO DISCONNECT POWER CORD COULD RESULT IN PERSONAL INJURY.**

- 1) Remove motor cover. See Motor Cover Removal on Page 7.
- 2) Remove plastic filler cap, Item A, Fig. 23 on top of tank.
- 3) Remove small screw, Item B, Fig. 23 from end of tank and place a rag under this screw hole.
- 4) Fill tank with a LIGHT GRADE of mineral oil until oil starts to run out of small screw hole.
- 5) Replace small screw, Item B, Fig. 23 in end of tank.
- 6) Replace plastic filler cap, Item A, Fig. 23.
- 7) Replace motor cover. See Replacement of Motor Cover on Page 7.

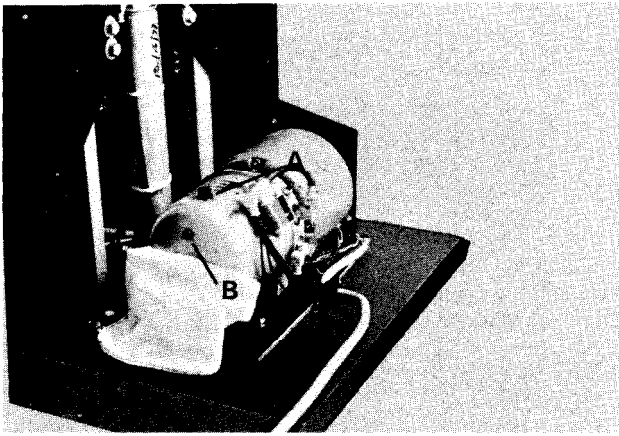

Fig. 23

## OIL LEAKS

**DANGER: HYDRAULIC OIL IN THIS EQUIPMENT IS UNDER HIGH PRESSURE WHEN EQUIPMENT IS IN OPERATION. NEVER CHECK OR ATTEMPT TO REPAIR ANY OIL LINE WITHOUT FIRST SHUTTING OFF THIS EQUIPMENT AND UNPLUGGING THE POWER CORD.**

Oil leaks can be caused by defective or damaged hose lines, hose or pipe fittings, "O" rings, or cylinder rod seals. If an oil leak appears in any area, determine exact location of leak.

- 1) If a leak is located at a pipe fitting, tighten the fitting a turn or two. If this does not eliminate the leak, back the fitting out and use pipe sealer on the threads. If the threads are damaged, replace the fitting.
- 2) If a leak is located at a hose fitting, try tightening the fitting. If this does not eliminate the leak, replace the "O" ring.

To replace the "O" ring, remove the hose fitting from the cylinder and remove the defective "O" ring. Place a new "O" ring in position, install the hose fitting, and tighten fitting securely.

## CYLINDER LEAKS

If a cylinder is leaking, replace the cylinder. See Removal and Replacement of Hydraulic Cylinders on pages 9, 10, 11, 12 & 13.

## HOSE LINE LEAKS

If a hose line is leaking, remove and replace the complete hose assembly.

To replace the short hose on the pump, loosen both fittings with a 1/2" wrench, remove defective hose, and replace with new hose tightening both fittings securely with a 1/2" wrench.

To replace the power hose (valve end of cylinders) or the return hose (rod end of cylinders) use the following procedure:

**DANGER: WHEN CHANGING A HOSE, NOTE HOW THE WIRES, HOSES, HOSE FITTINGS, AND NYLON TIES ARE POSITIONED SO THAT THEY MAY BE REPLACED EXACTLY THE SAME WAY OR DAMAGE TO THE WIRES AND HOSES MAY**

**OCCUR RESULTING IN ELECTRICAL SHOCK OR EQUIPMENT DAMAGE. See Fig. 14, 15, 16, 18, & 19.**

**DANGER: DISCONNECT POWER CORD FROM WALL RECEPTACLE. FAILURE TO DISCONNECT POWER CORD COULD RESULT IN PERSONAL INJURY.**

- 1) Remove motor cover and shrouds. See Removal of Motor Cover and Shrouds on Page 7.
  - 2) Remove back cover shroud from back section by removing (4) screws, Item A, Fig. 3.
  - 3) Place new hose along side of damaged hose before removing defective hose.
  - 5) Remove fittings and nylon ties of defective hose, one at a time, replacing with fittings of new hose and replacing nylon ties. Begin at back raising cylinder, then tilt cylinder then foot cylinder, then base cylinder, and then pump.
  - 6) After installation of new hose, check to see that all cords and hoses work freely and are clear of obstructions and that all fittings are tight.
  - 7) Place back cover shroud in position, align holes, and install (4) #6 x 1/4" screws, Item A, Fig. 3.
  - 8) Temporarily plug the power cord into an electrical outlet and extend and retract each cylinder several times to purge the system of air.
- DANGER: DISCONNECT POWER CORD FROM WALL RECEPTACLE. FAILURE TO DISCONNECT POWER CORD COULD RESULT IN PERSONAL INJURY.**
- 9) If loss of hydraulic fluid was excessive during repair, oil must be added to the system. Oil level should be checked and oil replenished if required. See Adding Oil to Hydraulic System on Page 13.
  - 10) Replace shrouds and motor cover. See Replacement of Shrouds & Motor Cover on Page 7.

## FOOTSWITCH

### Removal and Replacement of Footswitch

**DANGER: DISCONNECT POWER CORD FROM WALL RECEPTACLE. FAILURE TO DISCONNECT POWER CORD COULD RESULT IN PERSONAL INJURY.**

To remove the footswitch from the cord.

- 1) Remove the cover from the footswitch by removing (2) #10-32 x 3/8" machine screws, one from each end of the footswitch, and (3) #10-24 x 3/8" self tapping screws along the back of the footswitch.
- 2) Disconnect cord by pulling apart the (7) quick connect wire connectors and removing the (1) #10-24 x 3/8" self tapping screw, Item A, Fig. 24.

- 3) Grasp strain relief bushing with hand pliers (See Special Tools on Page 19), squeeze tab on bushing, and pull bushing out of hole in footswitch. See Fig. 24.

To replace the footswitch on the cord.

- 4) Position strain relief bushing on the cord, close the bushing, grasp bushing with the hand pliers squeezing the tab, and push bushing into hole in footswitch. See Fig. 24.
- 5) Connect cord to footswitch wires by mating the (7) quick connect wire connectors, matching the wire colors on the cord wires and footswitch wires.
- 6) Install the (1) HO-24 x 3/8" self tapping screw, Item A, Fig. 24 through the green grounding wire terminal.
- 7) Place cover on footswitch, align holes, and install (2) #10-32 x 3/8" machine screws, one on each end of footswitch, and (3) #10-24 x 3/8" self-tapping screws along the back of the footswitch.

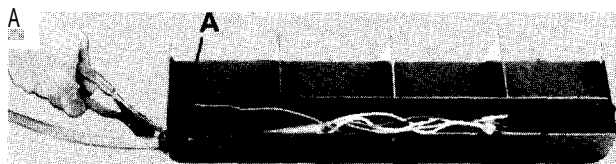

Fig. 24

### Removal and Replacement of Foot Control Switches

**DANGER: DISCONNECT POWER CORD FROM WALL RECEPTACLE. FAILURE TO DISCONNECT POWER CORD COULD RESULT IN PERSONAL INJURY.**

- 1) Remove cover from footswitch by removing (2) #10-32 x 3/8" machine screws, one from each end of the footswitch, and (3) #10-24 x 3/8" self tapping screws along the back of the footswitch.
- 2) Remove foot pedal cover by removing screw, Item A, Fig. 26 and lifting cover upwards and towards front of footswitch.
- 3) Remove defective switch from bracket by removing the (2) mounting screws and nuts, Item B, Fig. 25.
- 4) Place new switch in position on bracket, align holes, and install (2) each of #3-48 x 1/2" machine screws, #3 shakeproof internal lockwashers, and #3-48 hex nut, Item B, Fig. 25.
- 5) Remove wires one at a time from defective switch and install on corresponding terminal of new switch. See Wiring Diagram on Page 27.
- 6) Place foot pedal cover in position, align holes, and install (1) #10-32 x 1/2" machine screw and

- (1) #10 shakeproof internal lockwasher, Item A, Fig. 25.

- 7) Place cover on footswitch, align holes, and install (2) #10-32 x 3/8" machine screws, one on each end of footswitch, and (3) #10-24 x 3/8" self-tapping screws along the back of the footswitch.

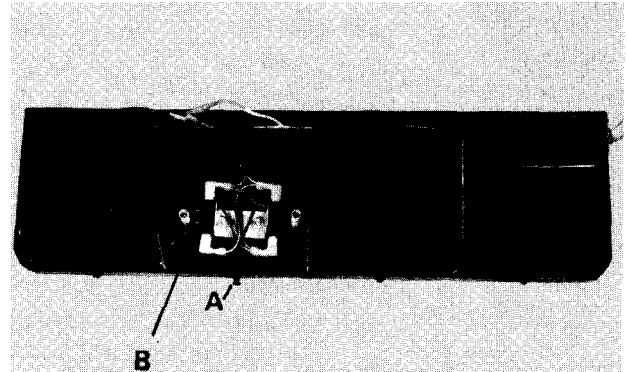

Fig. 25

### Removal and Replacement of Footswitch Cord

**DANGER: DISCONNECT POWER CORD FROM WALL RECEPTACLE. FAILURE TO DISCONNECT POWER CORD COULD RESULT IN PERSONAL INJURY.**

- 1) Remove motor cover, front outer shroud (foot end), and front inner shroud (foot end). See Removal of Motor Cover & Shrouds on Page 7.
- 2) Remove footswitch from cord. See Removal of Footswitch on Page 14.
- 3) Remove strain relief bushing, Item C, Fig. 22 from cord by grasping bushing with hand pliers (See Special Tools on Page 19), squeezing tab on bushing, and pulling bushing out of hole in bracket.
- 4) Lay new footswitch cord along side of defective cord.
- 5) Remove wires of defective cord from terminal board and replace with wires of new cord, removing and replacing one wire at a time. See Wiring Diagram on Page 27.
- 6) Follow defective cord, removing and replacing on new cord any nylon ties and cable clamps.
- 7) Insert new cord through bracket (See Fig. 22) and install strain relief bushing using the hand pliers, (See Special Tools on Page 19).
- 8) Install cord in footswitch. See Replacing Footswitch on Cord on Page 14.
- 9) Replace motor cover and shrouds. See Replacement of Motor Cover & Shrouds on Page 7.

### Foot Control Switch Adjustment

If when the foot pedal is depressed the switch does not activate (audible click), the "stops" must be adjusted.



- 1) Disconnect the power cord from the wall receptacle.
- 2) Loosen lock nut, Item A, Fig. 26 under the malfunctioning switch.
- 3) While depressing the pedal, use an allen wrench to turn the "stop" counterclockwise until an audible click is heard.
- 4) After the click is heard, adjust the "stop" an additional 1/2 turn counterclockwise.

**DANGER: DO NOT ADJUST THE STOP MORE THAN AN ADDITIONAL 1/2 TURN AFTER AUDIBLE CLICK IS HEARD. ADJUSTING THE STOP MORE THAN 1/2 TURN MAY RESULT IN DAMAGE TO THE SWITCH OR PERSONAL INJURY.**

- 5) While holding the "stop" in position with an allen wrench, tighten the lock nut, Item A, Fig. 26 securely.

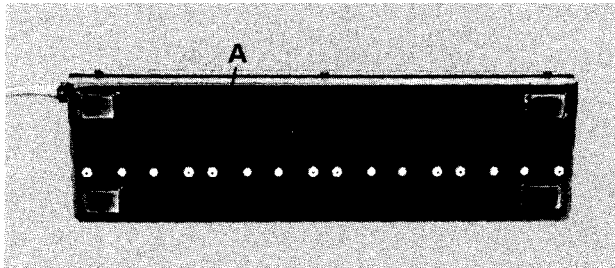

Fig. 26

## REMOVAL AND REPLACEMENT OF POWER SYSTEM PARTS

**DANGER: BEFORE ATTEMPTING TO REMOVE AND REPLACE A POWER SYSTEM PART, DISCONNECT POWER CORD FROM WALL RECEPTACLE. FAILURE TO DISCONNECT POWER CORD COULD RESULT IN PERSONAL INJURY.**

### Removal and, Replacement of Power Cord

- 1) Remove motor cover. See Removal of Motor Cover on Page 7.
- 2) Remove strain relief bushing, Item A, Fig. 27 from cord by grasping bushing with hand pliers (See Special Tools on Page 19), squeezing tab on bushing, and pulling bushing out of hole in bracket.
- 3) Remove the black and white wires of old cord from terminal board, noting the position of the wires.
- 4) Remove (1) screw, Item B, Fig. 27 securing the green grounding wire to the table base.
- 5) Remove defective power cord from the table.
- 6) Install new power cord on table by inserting cord through the bracket (See Fig. 27), connecting the black and white wires to the terminal board, and installing the (1) #10-24 x 3/8" self tapping screw, Item B, Fig. 27 through the green grounding wire terminal to secure the ground wire to the table base.

- 7) Position strain relief bushing on the cord, close the bushing, grasp bushing with hand pliers squeezing the tab, and push bushing into hole in bracket. See Fig. 27.
- 8) Replace motor cover. See Replacement of Motor Cover on Page 7.

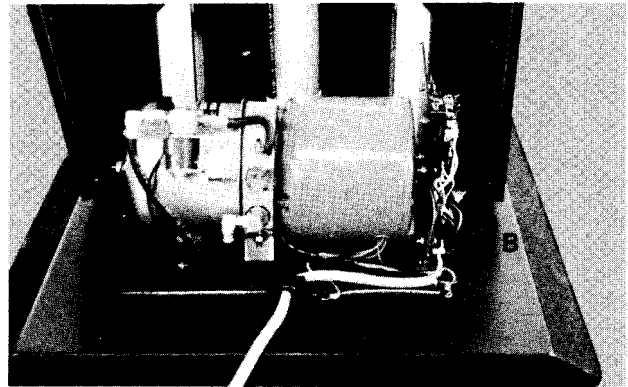

Fig. 27

### Removal and Replacement of Motor Capacitors

- 1) Remove front outer shroud (foot end) and front inner shroud (foot end). See Removal of Shrouds on Page 7.
- 2) Remove defective capacitor from its bracket (See Fig. 22). Capacitor is held in place by the protusions on each end of the capacitor engaging in a corresponding slot in the bracket.
- 3) Remove cap from defective capacitor.
- 4) Remove the wires from the defective capacitor and install on the new capacitor.
- 5) Place cap on new capacitor and install capacitor in the bracket, making sure the protusions on each end of the capacitor is fully engaged in the slot in the bracket. See Fig. 22.
- 6) Replaceshrouds. See Replacement of Shrouds on Page 7.

### Removal and Replacement of Anticavitation Solenoid Valve

The anticavitation solenoid valve Item A, Fig. 28 will prevent cylinder extension when the cylinder solenoid is unenergized.

To remove and replace the anticavitation solenoid valve.

- 1) Remove motor cover. See Removal of Motor Cover on Page 7.
- 2) Remove the solenoid wires from terminal board. See Wiring Diagram on Page 27.
- 3) Remove (2) hose fittings from the valve.
- 4) Remove anticavitation valve from table by removing (2) screws, Item B, Fig. 28.
- 5) Place new anticavitation valve in position, align holes, and install (2) #8-32 x 3/8" screws, Item B, Fig. 28.
- 6) Install the (2) hose fittings on the new valve.

- 7) Install the solenoid wires on the terminal board. See Wiring Diagram on Page 27.
- 8) If loss of hydraulic fluid was excessive during repair, oil must be added to the system. Oil level should be checked and oil replenished if required. See Adding Oil to Hydraulic System on Page 13.
- 9) Replace motor cover. See Replacement of Motor Cover on Page 7.

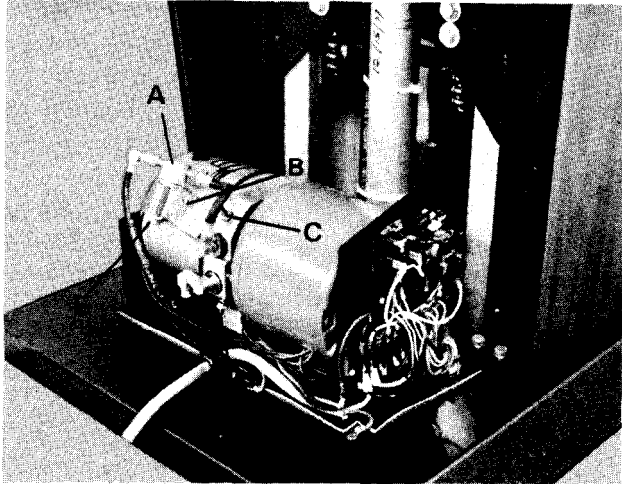

Fig. 28

### Removal and Replacement of Time Delay Relay

The time delay relay, Item A, Fig. 29 delays the opening of the cylinder solenoids for 1/10 of a second to avoid momentary drop in up actuations.

To remove and replace the relay:

- 1) Remove motor cover. See Removal of Motor Cover on Page 7.
- 2) Remove defective time delay relay by removing (1) nut and (1) screw, Item B, Fig. 29.
- 3) Place new time delay relay in position, align holes, and install (1) #6-32 hex nut and (1) #6-32 x 1" pan, head screw, Item B, Fig. 29.

**DANGER: THE LOCATOR PIN ON THE BACK OF THE TIME DELAY RELAY MUST BE IN THE HOLE ON THE MOTOR BASE. FAILURE TO DO THIS COULD RESULT IN ELECTRICAL SHOCK.**

- 4) Remove wires from defective time delay relay and install on corresponding terminals on new time delay relay. See Wiring Diagram on Page 27.
- 5) Replace motor cover. See Replacement of Motor Cover on Page 7.

### Removal and Replacement of Ground Line Integrity Monitor (GLIM)

The GLIM, Item C, Fig. 29 will prevent application of line voltage to the table if the power cord is connected to a reverse polarity AC supply or to an AC supply without ground. A table equipped with a **GLIM CAN BE USED ONLY** on a 3-wire, grounded, non-isolated AC supply.

To remove and replace the GLIM:

- 1) Remove motor cover. See Removal of Motor Cover on Page 7.
- 2) Remove defective GLIM by removing (2) nuts, spacers, and screws, Item D, Fig. 29.
- 3) Place new GLIM in position, align holes, and install (2) #6-32 hex nuts, (2) 1/4" spacers, and (2) #6-32 x 3/4" screws, Item D, Fig. 29.
- 4) Remove wires from defective GLIM and install on corresponding terminals on new GLIM. See Wiring Diagram on Page 27.
- 5) Replace motor cover. See Replacement of Motor Cover on Page 7.

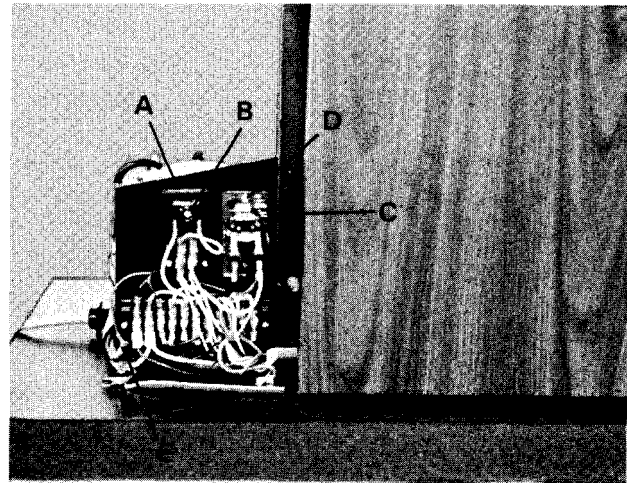

Fig. 29

### Removal and Replacement of Motor/Pump

The motor/pump is an integral unit and may be removed and replaced as follows:

- 1) Remove motor cover, front outer shroud (foot end), and front inner shroud (foot end). See Removal of Motor Cover and Shrouds on Page 7.
- 2) Remove the (3) motor leads T1, T2, and T3 from terminal board. See Wiring Diagram on Page 27.
- 3) Remove the capacitors from the brackets and remove the wires from the capacitors. See Removal of Motor Capacitors on Page 16.
- 4) Loosen cable clamps and remove the capacitor leads from the clamps.
- 5) Remove the (4) hex nuts, Item A, Fig. 30 securing the motor base in place.
- 6) Tilt motor base and remove the (2) hex bolts securing the motor/pump to the motor base.
- 7) Loosen the hex nut on the end of the oil reservoir that secures the tank to the motor base.
- 8) Remove the anticavitation solenoid valve from the bracket on the pump. See Removal of Anticavitation Solenoid Valve on Page 16.
- 9) Remove the short pump hose, Item B, Fig. 30 from the pump by removing the fitting with a 1/2" wrench.

10) Remove the power hose, Item C, Fig. 30 from the pump by removing the fitting with a 1/2" wrench.

11) Lift motor/pump off of the motor base while pulling the motor leads and capacitor leads through the bushing in the motor base.

12) Insert motor leads and capacitor-leads of new motor/pump through the bushing in the motor base.

13) Place new motor/pump on motor base, align holes on the underside and install (2) 1/2" lockwashers and (2) 1/2"-13 x 1" hex bolts.

Note: Be sure the stud on the end of the oil reservoir is in the slot on the end of the motor base.

14) Tighten the hex nut on the end of the oil reservoir to secure the tank to the motor base.

15) Replace power hose, Item C, Fig. 30 on pump, tightening the fitting securely with a 1/2" wrench.

16) Replace short pump hose, Item B, Fig. 30 on pump, tightening the fitting securely with a 1/2" wrench.

17) Replace anticavitation solenoid valve. See Replacement of Anticavitation Solenoid Valve on Page 16.

18) Place motor base on shock mounts, align holes, and install (4) 1/4" lockwashers and (4) 1/4"-20 hex nuts, Item A, Fig. 30.

19) Install cable clamps on capacitor leads and tighten clamps.

20) Install capacitor leads on capacitors and install capacitors in brackets. See Wiring Diagram on Page 27 and Replacement of Capacitors on Page 16.

21) Replace the (3) motor leads T1, T2, and T3 on the terminal board. See Wiring Diagram on Page 27.

22) If loss of hydraulic fluid was excessive during repair, oil must be added to the system. Oil level should be checked and oil replenished if required. See Adding Oil to Hydraulic System on Page 13.

23) Replace motor cover and shrouds. See Replacement of Motor Cover and Shrouds on Page 7.

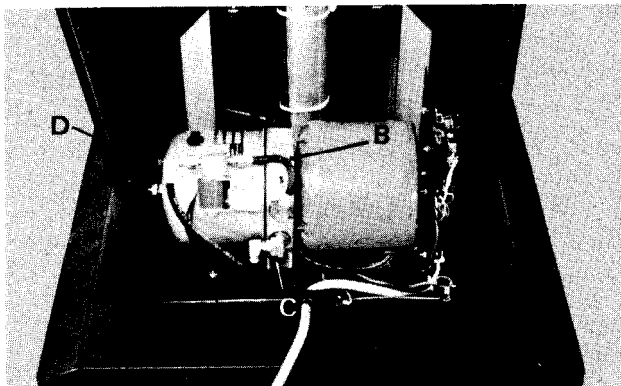

Fig. 30

## Removal and Replacement of Complete Motor/Pump Assembly

The motor/pump assembly complete with mounting bracket and all external hardware as shown in Fig. 30 may be removed and replaced as a single unit by:

1) Remove motor cover, front outer shroud (foot end), and front inner shroud (foot end). See Removal of Motor Cover and Shrouds on Page 7.

2) Remove the capacitors from the brackets and remove the wires from the capacitors. See Removal of Motor Capacitors on Page 16.

3) Loosen cable clamps and remove the capacitor leads from the clamps.

**DANGER: WHEN REMOVING THE WIRES FROM THE TERMINAL BOARD, NOTE THE POSITION OF THE WIRES SO THAT THEY MAY BE REPLACED ON THE SAME TERMINALS. FAILURE TO DO THIS COULD RESULT IN EQUIPMENT DAMAGE OR PERSONAL INJURY.**

4) Remove the (7) wires of the footswitch cord from the terminal board.

5) Remove the black and white wires of each cylinder from the terminal board.

6) Remove the black and whitewires of the power cord and receptacle from the terminal board.

7) Remove the green grounding wire from the motor base by removing (1) screw, Item E, Fig. 29.

8) Remove the (4) hex nuts, Item A, Fig. 30 securing the motor base in place.

9) Remove the power hose, Item C, Fig. 30 from the pump by removing the fitting with a 1/2" wrench.

10) Remove the return hose, Item D, Fig. 30 from the anticavitation solenoid valve by removing the fitting with a 1/2" wrench.

11) Remove the motor/pump assembly from the table.

12) Set new motor/pump assembly in place.

13) Replace return hose, Item D, Fig. 30 on the anticavitation solenoid valve and tighten fitting securely.

14) Replace power hose, Item C, Fig. 30 on the pump and tighten fitting securely.

15) Install the (4) hex nuts, Item A, Fig. 30.

16) Attach green grounding wire to motor base by installing (1) #10-24 x 3/4" screw, Item E, Fig. 29.

17) Install the black and white wires of the power cord and receptacle, the black and white wires of each cylinder, and the (7) wires of the footswitch cord on the terminal board. See Wiring Diagram on Page 27.

18) Install cable clamps on capacitor leads and tighten clamps.

19) Install capacitor leads on capacitors and install capacitors in brackets. See Wiring Diagram on

Page 27 and Replacement of Capacitors on Page 16.

- 20) If loss of hydraulic fluid was excessive during repair, oil must be added to the system. Oil level should be checked and oil replenished if required. See Adding Oil to Hydraulic System on Page 13.
- 21) Replace motor cover and shrouds. See Replacement of Motor Cover and Shrouds on Page 7.

## ADJUSTMENT OF FLOW CONTROLS

There are two flow controls on the pump to regulate the time for cylinder extension and cylinder retraction. These flow controls are set and locked in place at the factory and should not need adjustment. Should it ever become necessary to adjust the speed of the table use the following procedure:

“Up” Flow Control (Item C, Fig. 28). The “up” flow control is adjusted for a time of 13 seconds to raise the table to its highest position from its lowest position.

- 1) Loosen the locknut.
- 2) Turn set screw in a clockwise direction to decrease speed of table movement.
- 3) Turn setscrew in a counterclockwise direction to increase speed of table movement.
- 4) Adjust setscrew for an “up” time of 13 seconds.
- 5) After adjustment of setscrew, tighten the locknut.

“Down” Flow Control (Item D, Fig. 28). The “down” flow control is adjusted for a time of 12 seconds to lower the table from its highest position to its lowest position.

- 1) Loosen the locknut.
- 2) Turn setscrew in a clockwise direction to decrease speed of table movement.
- 3) Turn setscrew in a counterclockwise direction to increase speed of table movement.
- 4) Adjust setscrew for a “down” time of 12 seconds.
- 5) After adjustment of setscrew, tighten the locknut.

## SPECIAL TOOLS

Hand Pliers (Fig. 31) is used to remove and install the strain relief bushings. These pliers are manufactured by Heyman Manufacturing Co. and are available through their sales office in Waukesha, Wisconsin. When ordering, specify No. 29 Hand Pliers, Heyco Part #0022.

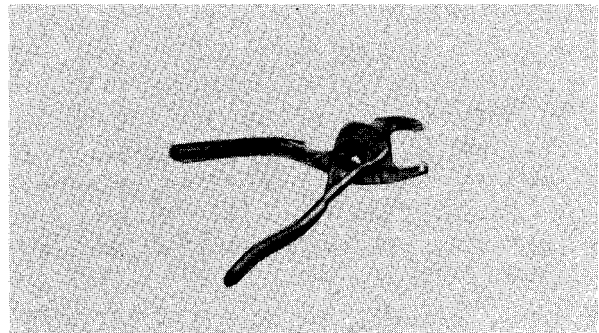

Fig. 31

## TROUBLE SHOOTING GUIDE

A table equipped with a Ground Line Integrity Monitor (GLIM) can be used only with a **3-wire, grounded, non-isolated** AC power supply. The GLIM will prevent operation of the table if the ground line resistance rises above approximately one megohm and/or sufficient fault current exists to develop a potential of 8 VRMS between ground and neutral.

Note: When a fault condition preventing the operation of the GLIM has been corrected, power must be removed and reapplied before equipment will operate.

A wiring diagram follows this troubleshooting guide and referral to it during troubleshooting will be helpful.

Conditions which could cause improper functioning of the power unit are listed below along with diagnosis and repair procedures.

**DANGER: DO NOT ATTEMPT ELECTRICAL CONTINUITY CHECKS OR ANY WIRING TESTS WITH THE TABLE PLUGGED INTO THE WALL OUTLET. FAILURE TO DISCONNECT POWER COULD RESULT IN ELECTRICAL SHOCK.**

Problem	Symptom	Probable Cause	Check	Correction
When all up and down Relay on GLIM does switches are depress- not actuate the mo- ed individually, table ment the table is will not actuate into plugged into a wall any up or down outlet. positions.		Unit not plugged into wall receptacle.	Check	Plug unit into wall receptacle.
		Blown Fuse	Check building fuse.	Replace building fuse if blown.
		Wall receptacle not grounded.	Wall receptacle must be grounded.	Plug table into a grounded wall receptacle.
		Wall receptacle wired incorrectly.	Wall receptacle wiring must be correctly polarized.	Plug table into a correctly wired receptacle.
		Pin 9 on GLIM not connected to grounding pin of attachment plug on power cord. Green grounding wires broken or disconnected.	Check continuity of green grounding wire and/or between pin 9 and motor base.	Replace if faulty connections.
			Check continuity of green grounding wire and/or between motor base and table base.	Replace if faulty connections.
			Check continuity of ground between table base and grounding pin of attachment plug on power cord.	Replace power cord if faulty and/or tighten connections.
	Defective GLIM	Unplug table from wall receptacle and temporarily bypass GLIM by disconnecting black wire from pin 4 and attaching it to pin 1 and disconnecting white wire from pin 6 and attaching it to pin 3. (See Wiring Diagram on page 27) Plug unit into wall receptacle and measure the voltage between ground and neutral (between green and white wires of power cord), if less than 6 VRMS and table will now actuate, the GLIM is defective.	Replace GLIM	

Problem	Symptom	Probable Cause	Check	Correction
Continued)	Relay on GLIM actuates the moment the table is plugged into wall outlet but motor does not run and no cylinder solenoid actuation (audible click)	Black wire of footswitch cord a broken or disconnected or black wire within footswitch broken or disconnected or defective microswitch in footswitch control.	Check continuity of black wires. Check connectors. Check continuity of microswitch.	Replace footswitch cord if faulty Replace black jumper wires in footswitch if faulty Replace defective microswitch.
	Motor does not run but capacitor cylinder solenoids actuate (audible click)	Capacitor burned out or loose terminals.	Check terminals.	Replace defective capacitor and/or tighten connections.
		Motor thermal overload switched on.	Allow motor to cool and recheck.	Do not run motor continuously.
	Motor does not run but motor hum is audible and cylinder solenoids actuate (audible click)	Motor and pump locked. Mechanical bind or defective motor.	Allow motor to cool and recheck.	Replace motor, pump if defective.
	Cylinder solenoids do not actuate but motor runs.	Defective time delay relay.	Unplug unit from wall receptacle and temporarily bypass time delay relay by disconnecting wire from #2 terminal and attaching it to #1 terminal. Check operation, if cylinders now actuate, relay is defective.	Replace time delay relay.
Motor and all electrical function properly.	Low on hydraulic oil.	Check oil level.	Add oil if necessary	
When all up and down switches are depressed individually, the table will not function when base up, tilt up, back up or foot up switch is actuated. Base down, tilt down, back down and foot down functions properly.	Motor runs and cylinder solenoids actuate (audible click). Defective pump		Pressure should be apparent in power hose, Item C, Fig. 30 when any up footswitch pedal is depressed.	Replace motor/pump if no pressure is apparent.
		Anticavitation solenoid valve solenoid burned out.	Pressure will be apparent in power hose, Item C, Fig. 30 when any up footswitch pedal is depressed. Check for slight magnetism at small cap, Point E, Fig. 28 on end of anticavitation solenoid valve when an up footswitch pedal is depressed.	Replace anticavitation solenoid valve if faulty.
		"Up" flow control may be closed.	Loosen locknut, turn setscrew counterclockwise, and recheck.	Set "up" time for 13 seconds.

Problem	Symptom	Probable Cause	Check	Correction
(Continued)	Motor does not run (up actuations only) but cylinder solenoids actuate (audible click).	Blue wire of footswitch cord broken or disconnected or blue wire within footswitch broken or disconnected.	Check continuity of blue wires. Check connectors.	Replace footswitch cord if faulty. Replace blue jumper wire in footswitch if faulty.
When all switches are depressed individually, table will not function when base down, tilt down, back down or foot down switch is depressed. Base up, tilt up, back up, and foot up function properly.	Motor runs and Defective pump. cylinder solenoids actuate (audible click)	Defective pump.	Pressure should be apparent in pump hose, Item B, Fig. 30 when any down footswitch pedal is depressed.	Replace motor/pump if no pressure is apparent.
		Anticavitation solenoid valve.	Pressure will be apparent in pump hose, Item B, Fig. 30 and no pressure should be apparent in return hose, Item D, Fig. 30 when any down footswitch pedal is depressed.	Replace anticavitation solenoid valve if pressure is apparent in return hose.
		"Down" flow control may be closed.	Loosen locknut, turn setscrew counter-clockwise, and recheck.	Set "down" time for 12 seconds.
When all switches are depressed individually, base up and base down does not function. All other actions function.	Motor does not run (downactuations only) but cylinder solenoids actuate (audible click).	Red wire of footswitch cord broken or disconnected or red wire within footswitch broken or disconnected.	Check continuity of red wires. Check connectors.	Replace footswitch cord if faulty. Replace red jumper wire in footswitch if faulty.
		White wire of footswitch cord broken or disconnected or white wire within footswitch broken or disconnected.	Check continuity of white wire. Check connectors.	Replace footswitch cord if faulty. Replace white jumper wire in footswitch if faulty.
Base up functions but not base down or base down functions but not base up. All other actions function.	Motor runs but base cylinder solenoid does not actuate (no audible click).	Cylinder solenoid burned out.	If above checks O.K.	Replace base cylinder.
		Footswitch out of adjustment.	Depress footswitch pedal and listen for audible click of microswitch.	Adjust footswitch if audible click.
When all switches are depressed individually, tilt up and tilt down does not function. All other actions function.	Motor does not run and no base solenoid actuation (no audible click).	Defective micro switch in footswitch control.	Check continuity of micro switch in on and off positions. See wiring diagram.	Replace micro switch if continuity does not conform to wiring diagram.
		Motor may or may not run and cylinder solenoid may or may not actuate.		
When all switches are depressed individually, tilt up and tilt down does not function. All other actions function.	Motor runs but tilt cylinder solenoid does not actuate (no audible click).	Orange wire of footswitch cord broken or disconnected or orange wire within footswitch broken or disconnected.	Check continuity of orange wire. Check connectors.	Replace footswitch cord if faulty. Replace orange jumper wire in footswitch if faulty.
		Cylinder solenoid burned out.	If above checks O.K.	Replace tilt cylinder.

Problem	Symptom	Probable Cause	Check	Correction
Tilt up functions but not tilt down or tilt down functions but not tilt up. All other actions function.	Motor does not run and no tilt solenoid actuation (no audible click).	Footswitch out of adjustment.	Depress footswitch Adjust pedal and listen for no audible click of microswitch.	Adjust footswitch if audible click.
	Motor may or may not run and cylinder solenoid may or may not actuate.	Defective micro switch in footswitch control.	Check continuity of micro switch in on and off positions. See wiring diagram.	Replace micro switch if continuity does not conform to wiring diagram.
When all switches are depressed individually, back up and back down does not function. All other actions function.	Motor runs but back cylinder solenoid does not actuate (no audible click).	White/black wire of footswitch cord broken or disconnected or white/black wire within footswitch broken or disconnected.	Check continuity of white/black wire. Check connectors.	Replace footswitch cord if faulty. Replace white/black jumper wire in footswitch if faulty.
		Cylinder solenoid burned out.	If above checks O.K.	Replace back cylinder.
Back up functions but not back. down or back down functions but not back up. All other actions function.	Motor does not run and no back solenoid actuation. (no audible click).	Footswitch out of adjustment.	Depress footswitch Adjust pedal and listen for no audible click of microswitch.	Adjust footswitch if audible click.
	Motor may or may not run and cylinder solenoid may or may not actuate.	Defective micro switch in footswitch control.	Check continuity of micro switch in on and off positions. See wiring diagram.	Replace micro switch if continuity does not conform to wiring diagram.
When all switches are depressed individually, foot up and foot down does not function. All other actions function.	Motor runs but foot cylinder solenoid does not actuate (no audible click).	Red/black wire of footswitch cord broken or disconnected or red/black wire within footswitch broken or disconnected.	Check continuity of red/black wire. Check connectors.	Replace footswitch cord if faulty. Replace red/black jumper wire in footswitch if faulty.
		Cylinder solenoid burned out.	If above checks O.K.	Replace foot cylinder.
Foot up functions but not foot down or foot down functions but not foot up. All other actions function.	Motor does not run and no foot solenoid actuation. (no audible click).	Footswitch out of adjustment.	Depress footswitch Adjust pedal and listen for no audible click of microswitch.	Adjust microswitch if audible click.
	Motor may or may not run and cylinder solenoid may or may not actuate.	Defective micro switch in footswitch control.	Check continuity of micro switch in on and off positions. See Wiring Diagram.	Replace micro switch if continuity does not conform to wiring diagram.
Either base, tilt, back or foot cylinder will not hold position. May drift down slowly.	Motor and all electrical functions properly.	Faulty micro switch in footswitch control. May be holding cylinder solenoid in energized position.	Check for current with test lamp at cylinder terminal with switch in off position. Check both up and down micro switches. See wiring diagram.	If there is current at cylinder terminal with switch in off position, replace micro switch.
		Dirt particle in cylinder solenoid valve or faulty cylinder solenoid.	Flush dirt particle to reservoir by running cylinder in and out about 10 times if this does not help, a replacement cylinder will be needed.	Replace cylinder.



Problem	Symptom	Probable Cause	Check	Correction
Back may be lifted or tilt may drift up with weight on the back section.	Motor and all electrical functions properly.	Defective anticavitation solenoid valve.	Lift on back section, if it raises with hand pressure, anticavitation valve is defective.	Replace anticavitation solenoid valve.
Excessive sideways play of table base.	Excessive sideways play of table base.	Loose stabilizing chains.	Check chains for tightness.	Tighten chains.

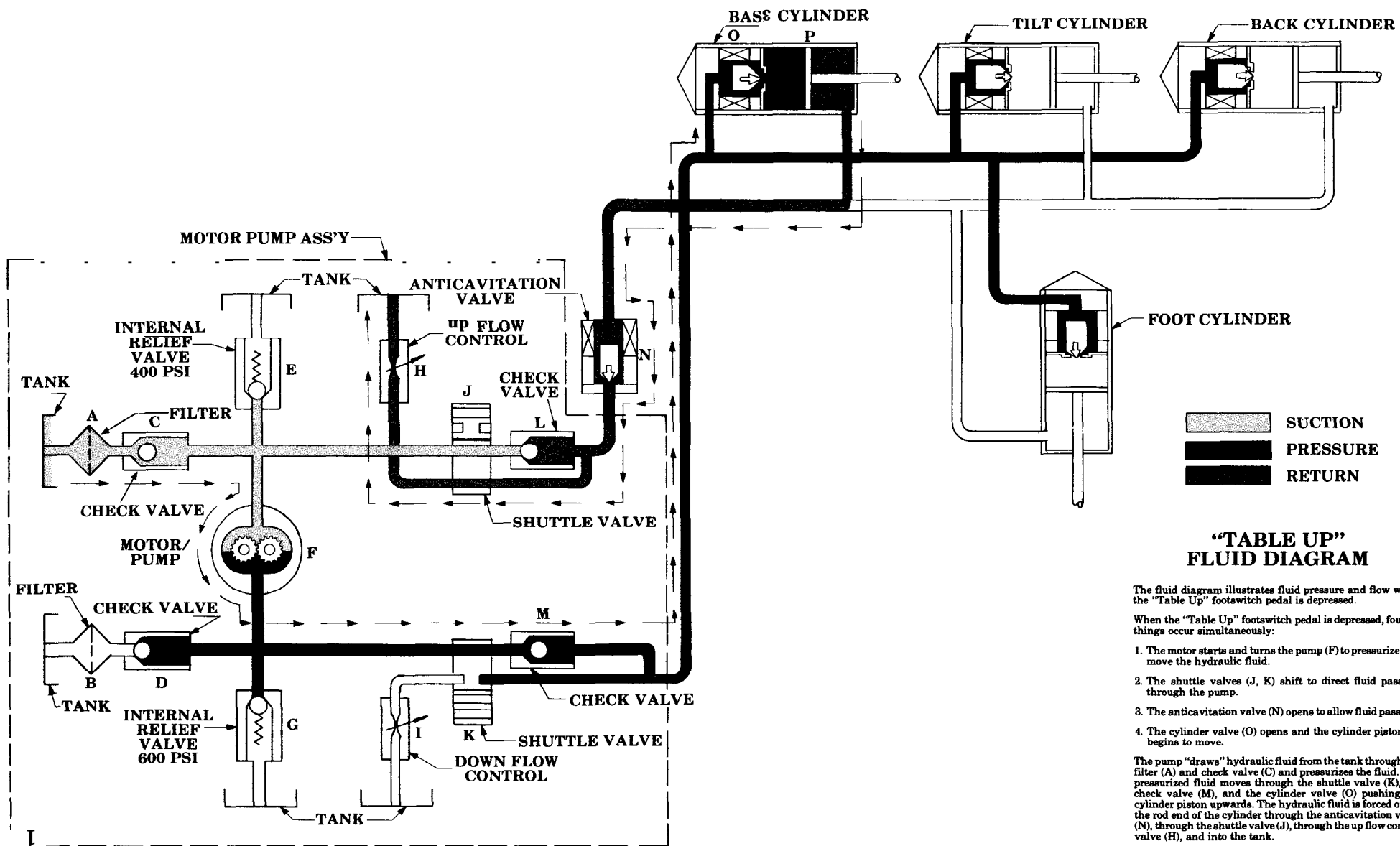

### "TABLE UP" FLUID DIAGRAM

The fluid diagram illustrates fluid pressure and flow when the "Table Up" footswitch pedal is depressed.

When the "Table Up" footswitch pedal is depressed, four (4) things occur simultaneously:

1. The motor starts and turns the pump (F) to pressurize and move the hydraulic fluid.
2. The shuttle valves (J, K) shift to direct fluid passage through the pump.
3. The anticavitation valve (N) opens to allow fluid passage.
4. The cylinder valve (O) opens and the cylinder piston (P) begins to move.

The pump "draws" hydraulic fluid from the tank through the filter (A) and check valve (C) and pressurizes the fluid. The pressurized fluid moves through the shuttle valve (K), the check valve (M), and the cylinder valve (O) pushing the cylinder piston upwards. The hydraulic fluid is forced out of the rod end of the cylinder through the anticavitation valve (N), through the shuttle valve (J), through the up flow control valve (H), and into the tank.

When the piston reaches the end of its stroke, the piston stops and the pressurized fluid returns to the tank through the internal relief valve (G).

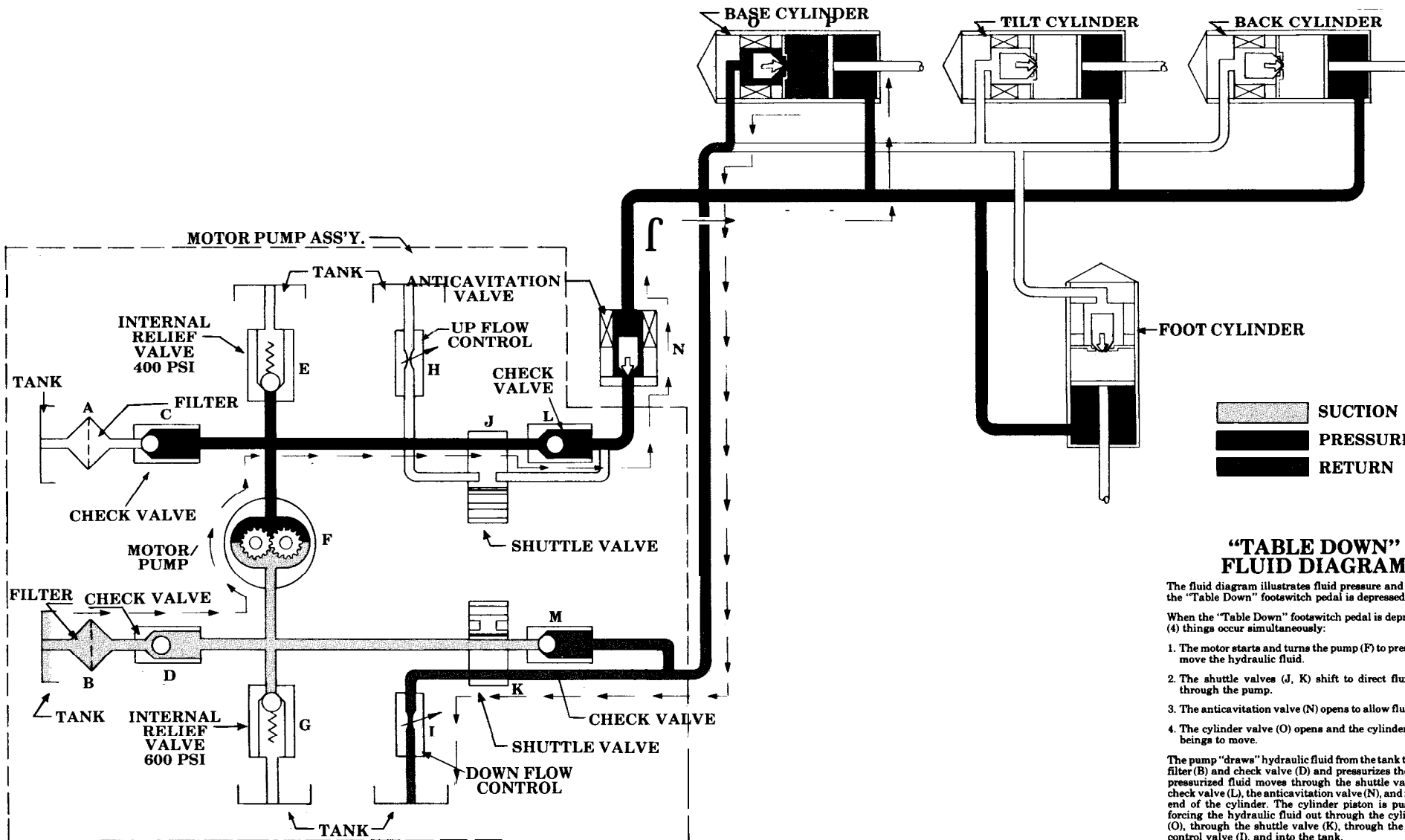

SUCTION  
 PRESSURE  
 RETURN

### “TABLE DOWN” FLUID DIAGRAM

The fluid diagram illustrates fluid pressure and flow when the “Table Down” footswitch pedal is depressed.

When the “Table Down” footswitch pedal is depressed, four (4) things occur simultaneously:

1. The motor starts and turns the pump (F) to pressurize and move the hydraulic fluid.
2. The shuttle valves (J, K) shift to direct fluid passage through the pump.
3. The anticavitation valve (N) opens to allow fluid passage.
4. The cylinder valve (O) opens and the cylinder piston (P) begins to move.

The pump “draws” hydraulic fluid from the tank through the filter (B) and check valve (D) and pressurizes the fluid. The pressurized fluid moves through the shuttle valve (J), the check valve (L), the anticavitation valve (N), and into the rod end of the cylinder. The cylinder piston is pushed down forcing the hydraulic fluid out through the cylinder valve (O), through the shuttle valve (K), through the down flow control valve (I), and into the tank.

When the piston reaches the end of its stroke, the piston stops and the pressurized fluid returns to the tank through the internal relief valve (E).

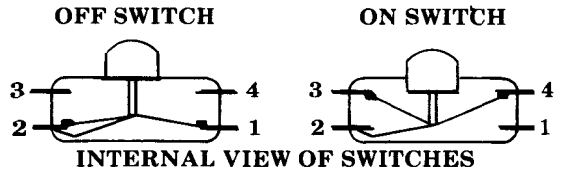

NOTE: IF AN UP SWITCH AND A DOWN SWITCH IS ENERGIZED AT THE SAME TIME; THE CIRCUIT BECOMES INOPERATIVE

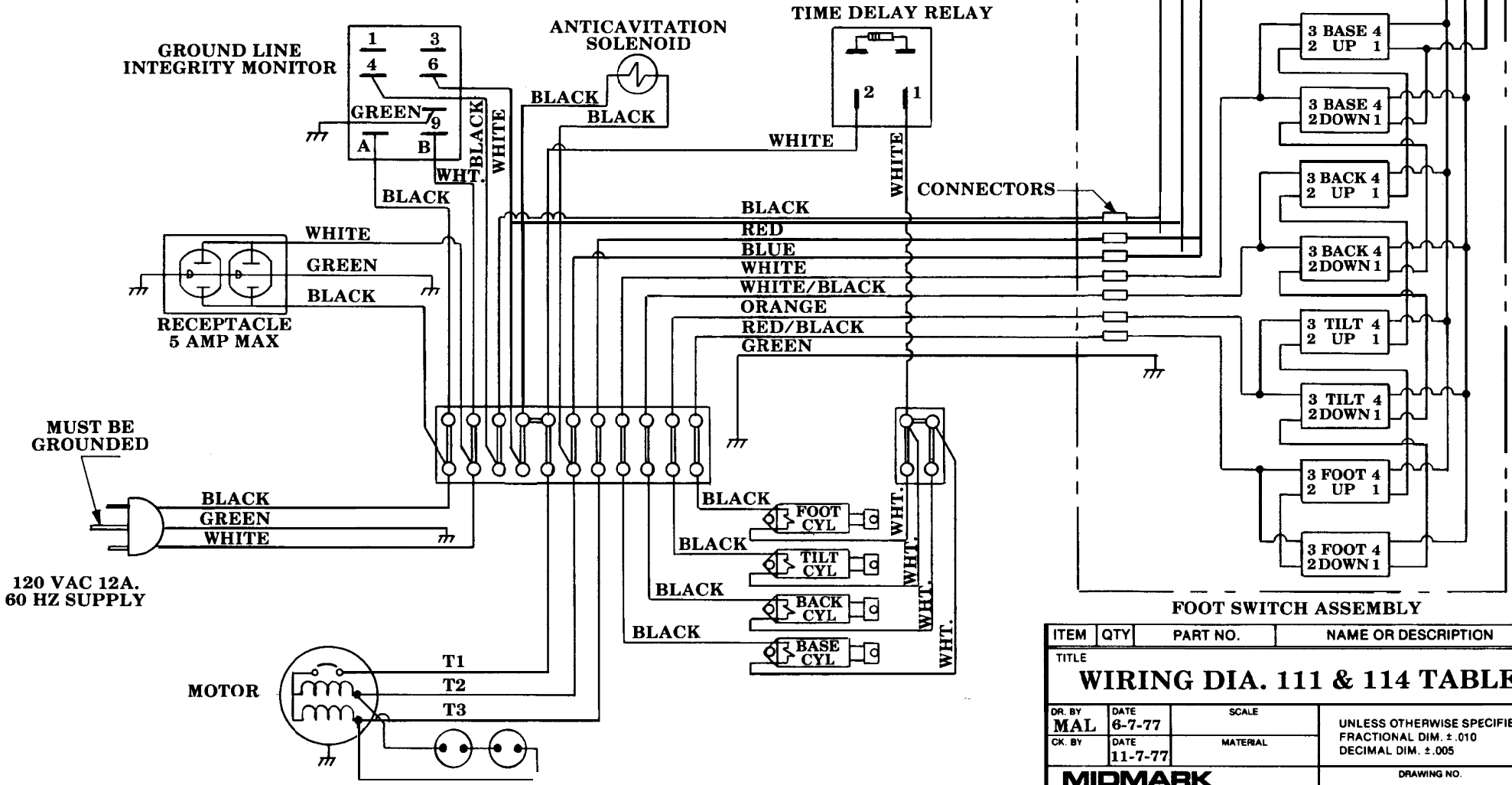

ITEM	QTY	PART NO.	NAME OR DESCRIPTION
TITLE			
<b>WIRING DIA. 111 &amp; 114 TABLE</b>			
DR. BY	DATE	SCALE	UNLESS OTHERWISE SPECIFIED FRACTIONAL DIM. ±.010 DECIMAL DIM. ±.005
MAL	6-7-77		
CK. BY	DATE	MATERIAL	
	11-7-77		
MIDMARK MEDICAL			DRAWING NO.
MIDMARK CORPORATION, VERSAILLES, OHIO 43081-9999			<b>003-0111-00</b>

ECO | DATE | REVISION | I | TD

## 114 Repair Parts List

Part Number	Description	Serial No. Range
<b>Upholstery</b>		
None Available	None Available	None Available
<b>Panels</b>		
None Available	None Available	None Available
<b>Hydraulic</b>		
002-0001-00	Base Cylinder	All
002-0002-00	Tilt Cylinder	All
002-0003-00	Back / Foot Cyl	All
<del>002-0012-00</del>	Return Hose	Prior to 37420
<del>002-0021-00</del>	Return Hose	37420 & up / L1000 - 1139
<del>002-0014-00</del>	Power Hose	All five diget and L1000-1139
<del>002-0031-00</del>	Pump Hose	Prior to 37420
<del>002-0032-00</del>	Pump Hose	37420 & up / L1000 - 1139
002-0117-00	Pump Hose	L1139 & Up
<del>002-0118-00</del>	Return Hose (Pump to Base)	L1139 & Up
002-0119-00	Power Hose (Pump to Base)	L1139 & Up
002-0120-00	Return Hose (Base Cylinder)	L1139 & Up
002-0121-00	Power Hose (Base to Tilt)	L1139 & Up
002-0122-00	Return Hose (Base to Tilt)	L1139 & Up
002-0123-00	Power Hose (Tilt to Foot)	L1139 & Up
002-0124-00	Return Hose (Tilt to Foot)	L1139 & Up
002-0125-00	Power Hose (Tilt to Back)	L1139 & Up
002-0126-00	Return Hosse (Tilt to Back)	L1139 & Up
002-0178-00	Return Hose (Tilt to Back)	L1139 & Up
002-0036-00	Down Solenoid Valve Coil	Prior to 37420
002-0037-00	Down Solenoid Valve Coil	37420 & up / L1000 - 1139
002-0038-00	Anticavitation Valve	All
014-0056-00	Mineral Oil	
002-0034-00	Motor Pump (Obsolete)	Prior to 37420
002-0035-00	Motor Pump (Obsolete)	37420 & up / L1000 - 1139
002-0127-00	Motor Pump	L1139 - 1985
002-0133-00	Motor Pump	L1985 - present
014-0168-00	Shuttle Valve	L1050 - present
014-0169-00	Shaft Seal - Motor Pump	All MTE Pumps

<b>Electrical</b>		
002-0041-00	Time Delay Relay	All
	GLIM (Obsolete)	
002-0040-00	Power Cord	All
002-0043-00	Capacitor 64-77 MFP	
002-0044-00	Capacitor 124-149 MFP	
002-0310-00	Capacitor Retrofit Kit	
002-0045-00	Foot Control Switch	All
002-0048-00	Footswitch Cord	All
015-0424-00	Auto Return Switch-Green	
015-0376-00	Auto Return Switch - Red	
015-0381-00	Return Limit Switch	L1228-1342
<del>015-0421-00</del>	Return Limit Switch	L1342 - present
015-0374-00	Auto Return Relay	
<b>Miscellaneous</b>		
029-1487-01	Headlock Assembly (Black)	All
016-0082-00	Mechanical Lock (Foot)	All

## COMMENTS

The Technical Publications Department of Midmark Corporation takes pride in its publications. We are sure that our manuals will fill all of your needs when you are performing scheduled maintenance, servicing, or repairs on a Midmark product.

However, if you find any errors or feel that there should be a change, addition, or deletion to a manual, please let us know!

**Page(s) and Paragraph(s) Needing Changed:**

**Description of Error or Desired Change:**

Please fax or mail a copy of this completed comment sheet to:

Midmark Corporation  
ATTN: Technical Publications Department  
60 Vista Drive  
Versailles, Ohio 45380  
Fax: (937) 526-5542

# FAX ORDERING FORM

(SERVICE PARTS ONLY)

**NOTES:**

- ALL **BLOCKED** AREAS MUST BE COMPLETED.
- USE FOR NON-WARRANTY FAX ORDERS ONLY. WARRANTY ORDERS MUST BE TELEPHONED IN (1-800-MIDMARK).

<b>ATTENTION: SERVICE DEPARTMENT FAX#: 877-249-1793</b>				
ACCT #: _____		P.O. #: _____		DATE: _____
NAME: _____		SHIP TO: _____		
ADDRESS: _____		_____		
CITY, ST.: _____		_____		
CONTACT: _____		_____		
PHONE: _____		_____		
<input type="checkbox"/> NON-EMERGENCY ORDER - TO SHIP WITHIN 72 HOURS IF PART(S) IN STOCK.		<b>METHOD OF SHIPMENT</b> <u>OTHER</u> _____		
<input type="checkbox"/> EMERGENCY ORDER - TO SHIP WITHIN 24 HOURS IF PART(S) IN STOCK (IF ORDER IS RECEIVED BEFORE 1:00 P.M. E.S.T).		UPS                                  FED EX		
SEND NOTIFICATION IF PARTS ARE NOT AVAILABLE TO SHIP WITHIN 24 HOURS VIA E-MAIL OR FAX TO: _____		<input type="checkbox"/> NEXT DAY A.M. <input type="checkbox"/> NEXT DAY A.M.		
		<input type="checkbox"/> NEXT DAY P.M. <input type="checkbox"/> NEXT DAY P.M.		
		<input type="checkbox"/> 2ND DAY <input type="checkbox"/> 2ND DAY		
		<input type="checkbox"/> GROUND <input type="checkbox"/> ECONOMY		
QTY.	PART #	DESCRIPTION (SPECIFY COLOR OF ITEM IF APPLICABLE)	COLOR CODE	PRICE/PER
			<b>TOTAL COST: \$</b>	





Midmark Corporation  
60 Vista Drive  
P.O. Box 286  
Versailles, Ohio 45380-0286  
937-526-3662  
Fax 937-526-5542  
midmark.com



Because we care.

Subject to change without notice.  
Refer to [www.Documark.com](http://www.Documark.com) for latest revision.